



Tulsa Winch

PO Box 1130
Jenks, OK 74037
Telephone (918) 298-8300
Fax: (918) 298-8301

1. DRAIN THE OIL FROM THE BRAKE.
2. DISCONNECT THE HOSES FROM THE BRAKE HOUSING (ITEM 1).
3. REMOVE THE MOTOR AND HOSES FROM THE WINCH BY REMOVING THE CAPSCREWS (ITEM 2).
4. LOOK INSIDE THE BRAKE DRIVER ASS'Y (ITEM 3). IF THERE ARE TWO RETAINING RINGS INSTALLED INSIDE THE DRIVER AS SHOWN IN FIG.-1 SKIP TO STEP 15.
5. EVENLY REMOVE THE FOUR CAPSCREWS (ITEM 4) ON THE BRAKE COVER. SPRING PRESSURE WILL RAISE THE COVER AS YOU LOOSEN THE CAPSCREWS.
6. REMOVE THE SPRINGS (ITEM 5) FROM THE PISTON.
7. REMOVE THE PISTON (ITEM 6) BY EVENLY SCREWING TWO 3/8-16 NC ALL-THREAD INTO THE TAPPED HOLES IN THE PISTON UNTIL THE PISTON IS CLEAR OF THE BRAKE HOUSING. CHECK THE TOP STATOR PLATE FOR SCORING, POLISH IF NECESSARY.
8. REMOVE THE BRAKE DRIVER ASS'Y (ITEM 3) FROM THE BRAKE HOUSING.
9. INSTALL TWO NEW RETAINING RINGS INTO THE BRAKE DRIVER ASS'Y (ITEM 3) AS SHOWN IN FIG.-1. *FOR ASSEMBLYS 82007, 81579, & 81536 USE THE ONE SMALL RETAINING RING IN INPUT DRIVER ASS'Y ON MOTOR SIDE AND ONE LARGE ONE ON OPPOSITE END OF DRIVER.*
10. RE-INSTALL THE BRAKE DRIVER ASS'Y INTO THE BRAKE HOUSING ALIGNING THE TEETH OF THE BRAKE DRIVER WITH THE TEETH OF THE FRICTION DISKS.
11. FOR TYPE "A" PISTON INSTALL ONE SEAL INTO THE BRAKE HOUSING BORE AND THE OTHER ONTO THE PISTON AS SHOWN IN FIG.-2.
FOR TYPE "B" PISTON INSTALL THE NEW O-RINGS AND BACKUP RINGS ONTO THE PISTON. AS SHOWN IN FIG.-3.
12. INSTALL THE BRAKE PISTON (ITEM 6) INTO THE BRAKE HOUSING.
13. INSERT THE SPRINGS INTO THE SPRING POCKETS IN THE PISTON. USE GREASE ON SPRINGS TO HOLD THEM IN PLACE WHILE WORKING IN A HORIZONTAL POSITION.
14. SELECT THE PROPER O-RING (ITEM 8) AND INSTALL IT ON THE BRAKE COVER (ITEM 7) THEN ATTACH THE BRAKE COVER TO THE BRAKE HOUSING USING FOUR CAPSCREWS (ITEM 4). *THE CAPSCREWS MUST BE EVENLY TIGHTENED TO PREVENT DAMAGING THE O-RING (ITEM 8).*
15. USING THE NEW O-RING (ITEM 9) RE-INSTALL THE MOTOR WITH THE FOUR CAPSCREWS (ITEM 2)
16. RE-CONNECT THE HOSES TO THE BRAKE HOUSING.
17. FILL THE BRAKE HOUSING WITH .50 QTS LIGHT WEIGHT NON-EP OIL. SUCH AS SAE 20 MOTOR OIL.
18. FOR COMPLETE SERVICE MANUAL GO TO [HTTP://WWW.TULSAWINCH.COM](http://www.tulsaWinch.com)

TYPE A
KIT #SA-4483

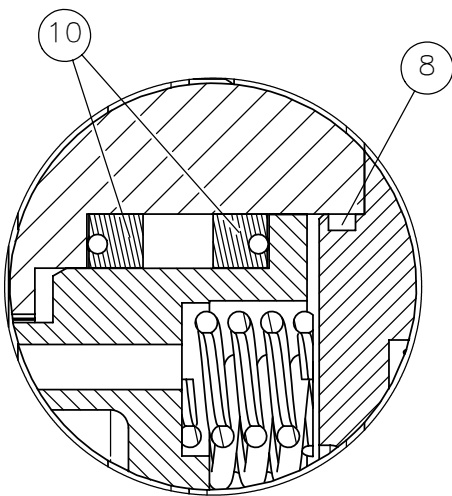
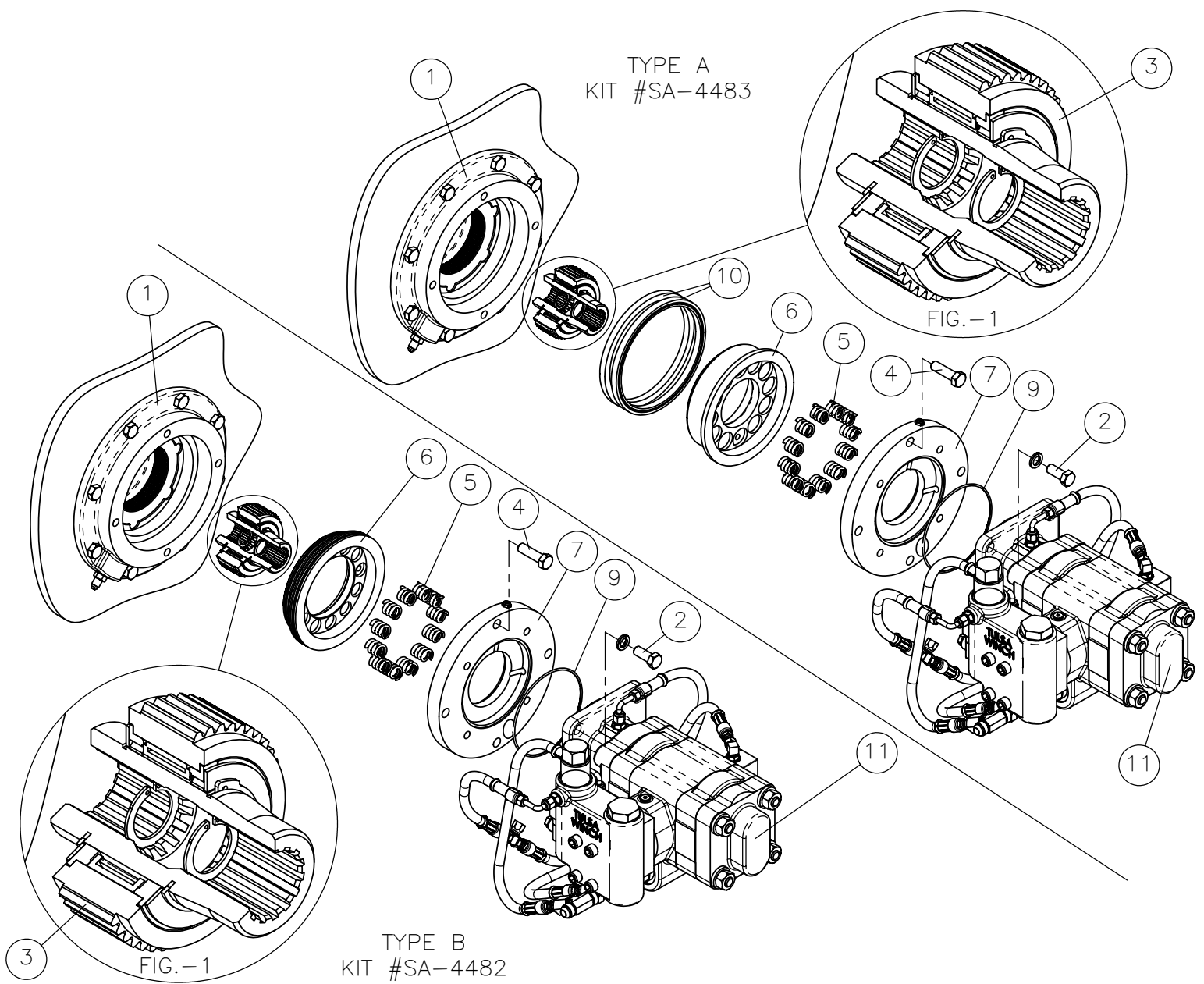

FIG.-2
(TYPE 1)

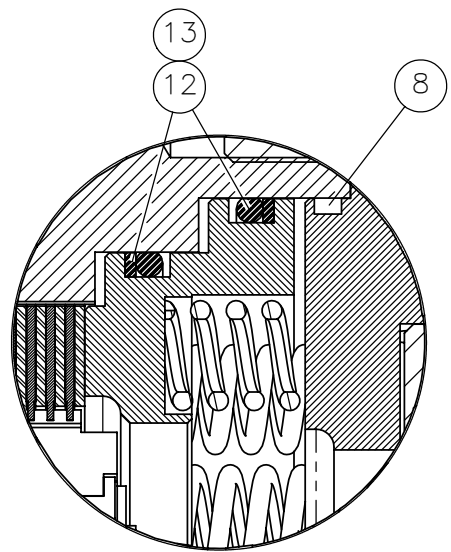

FIG.-3
(TYPE 2)