



Model 540 Hydraulic Planetary Winch

Line pull of 101,000 lbs. (45,800 kg)

The LANTEC® Model 540 Hydraulic Planetary Winch includes a hydraulic gear motor, spring-applied hydraulic-released multidisc brake with overrunning clutch and three planetary gear reductions. The Model 540 is a power in/power out winch with equal speed in both directions. LANTEC specializes in the custom designs, please inquire about special cable drums, hydraulic motors, handbrakes, freespool and ratchet and pawl options to meet your exact application needs.

CAUTION:
The last 5 wraps of cable must be left on the drum to assist the cable anchor in holding the load.

MODEL 540 Drum Torque 543,052 lb.in. (61,957 Nm) / Drum R.P.M. 10-76	Drum Number	Bare	Line Pull		Line Speed	
			lb.	kg	f.p.m.	m/m
107-109		Bare	101,032	45,828	30	9
		Mean	59,510	26,994	51	15
		Full	44,785	20,314	68	20
121-123		Bare	73,634	33,400	42	13
		Mean	48,813	22,142	63	19
		Full	40,600	18,416	75	23
131-133		Bare	57,925	26,275	53	16
		Mean	39,138	17,753	78	24
		Full	30,810	13,975	100	30
141-143		Bare	57,925	26,275	53	16
		Mean	35,320	16,021	86	26
		Full	26,330	11,943	116	35
151-153		Bare	43,880	19,904	70	21
		Mean	32,180	14,597	95	29
		Full	26,330	11,943	116	35

MODEL 541 Drum Torque 407,290 lb.in. (45,918 Nm) / Drum R.P.M. 14-35	Drum Number	Bare	Line Pull		Line Speed	
			lb.	kg	f.p.m.	m/m
107-109		Bare	75,775	34,372	40	12
		Mean	44,635	20,242	68	20
		Full	33,590	15,236	91	28
121-123		Bare	55,225	25,050	55	17
		Mean	36,610	16,606	84	26
		Full	30,450	13,812	100	30
131-133		Bare	43,445	19,707	70	21
		Mean	29,355	13,315	104	32
		Full	23,110	10,483	132	40
141-143		Bare	43,445	19,707	70	21
		Mean	26,490	12,016	115	35
		Full	19,750	8,959	155	47
151-153		Bare	32,910	14,928	93	28
		Mean	24,135	10,949	126	38
		Full	19,750	8,959	155	47

MODEL 542 Drum Torque 283,945 lb.in. (32,070 Nm) / Drum R.P.M. 20-59	Drum Number	Bare	Line Pull		Line Speed	
			lb.	kg	f.p.m.	m/m
107-109		Bare	52,808	23,954	58	18
		Mean	31,106	14,110	98	30
		Full	23,410	10,618	130	40
121-123		Bare	38,485	17,457	80	24
		Mean	25,515	11,574	120	37
		Full	21,220	9,625	145	44
131-133		Bare	30,277	13,733	101	31
		Mean	20,460	9,280	150	46
		Full	16,105	7,305	190	58
141-143		Bare	30,265	13,728	101	31
		Mean	18,450	8,369	166	50
		Full	13,760	6,242	222	68
151-153		Bare	22,940	10,405	133	40
		Mean	16,820	7,630	182	55
		Full	13,760	6,242	222	68

Performance based on a hydraulic volume of 90 gpm [340 l/min] at 2800 psi [193 bar] (2500 psi [172 bar] running)

Contact a TWG sales representative about other available configurations.

As a leader in product innovation, TWG is committed to the ongoing improvement of its equipment. TWG reserves the right to make changes to our products without notice.

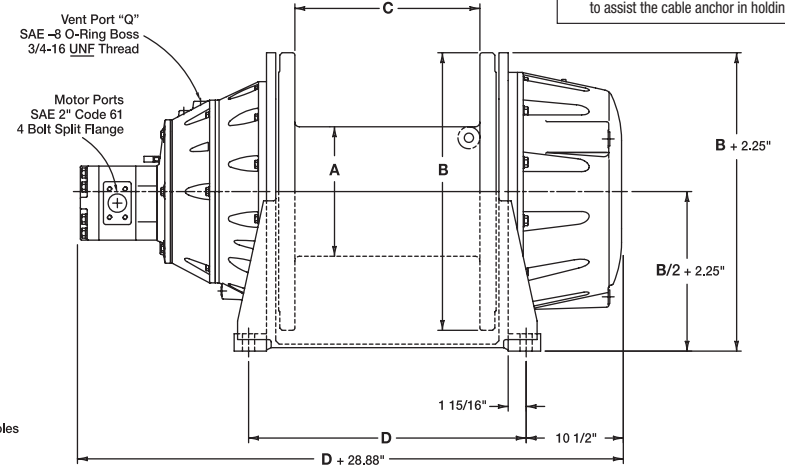
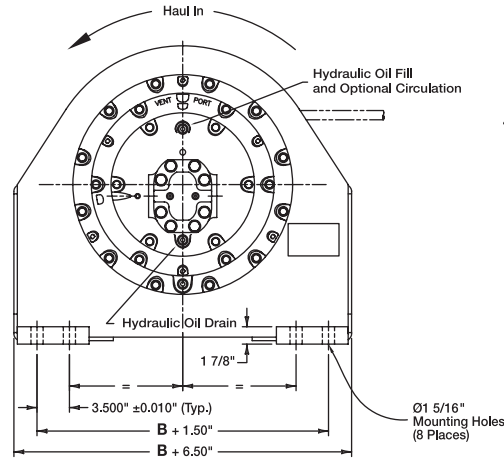

Drum	Dimensions				Cable Capacity Full Drum - No Allowance for Free-Flange											
	A - Barrel Dia.		B - Flange Dia.		C - Length		D - Bolt Centers		3/4"		7/8"		1"		1 1/8"	
	in	mm	in	mm	in	mm	in	mm	ft	mm	ft	mm	ft	mm	ft	mm
107	10	254	26	660	10	254	19.75	501.7	548	167	420	128	340	104	262	80
108	10	254	26	660	16	406	25.75	654.1	916	279	714	217	564	172	425	130
109	10	254	26	660	24	610	33.75	857.3	1420	433	1094	333	864	263	655	200
121	14	355	30	762	14	355	23.75	603.3	958	292	768	234	600	183	440	134
122	14	355	30	762	20	508	29.75	755.7	1406	428	1082	330	874	266	641	195
123	14	355	30	762	30	762	39.75	1009.7	2194	669	1700	518	1335	407	1000	305
131	18	457	36	914	14	355	23.75	603.3	1440	439	1050	320	826	252	621	189
132	18	457	36	914	20	508	29.75	755.7	2120	646	1470	448	1206	367	904	275
133	18	457	36	914	30	762	39.75	1009.7	3306	1008	2308	703	1842	561	1412	430
141	18	457	42	1067	20	508	30.25	768.4	3140	957	2100	640	1788	545	1224	373
142	18	457	42	1067	30	762	40.25	1022.4	4900	1494	3300	1005	2730	832	1914	583
143	18	457	42	1067	40	1016	50.25	1276.4	6530	1990	4400	1340	3674	1120	2600	792
151	24	610	42	1067	20	508	29.75	755.7	2590	789	1800	549	1476	450	1105	337
152	24	610	42	1067	30	762	39.75	1009.7	4040	1231	2826	861	2250	686	1728	527
153	24	610	42	1067	40	1016	49.75	1263.7	5388	1642	3771	1150	3030	924	2352	717

Other drum sizes available. For optimum performance in your operating conditions, please consult with the TWG/LANTEC Engineering Staff for accurate evaluation of all options and specifications.

LANTEC® is a registered brand of TWG, a global leader in standard and engineered winch, gearbox and electronic monitoring systems.

LANTEC®
5827 Production Way
Langley, BC, Canada V3A 4N5
Phone: 604-530-0737
Fax: 604-530-2889

TWG
PO Box 1130
Jenks OK 74037-1130 USA
Phone: 918-298-8300
www.team-twg.com