

GREER COMPANY

Crane Systems

LALT™ -1151L SYSTEM for LATTICE CRANES

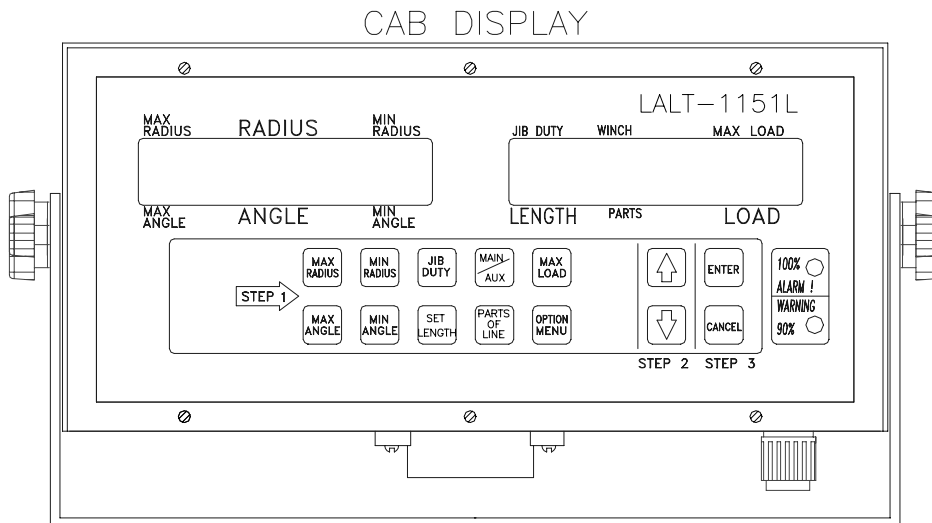

CALIBRATION MANUAL



WARNING

The LALT™ 1151L System for Lattice Cranes is designed to be used by the fully trained and experienced crane operator to aid in preventing overload and/or a Two-Block condition.

At no time may this System be used as a substitute for the well-trained operator or to replace the usual safety practices and precautions required for the safe setup and operation of cranes.

While in the Calibration Mode, only the Two-Block alarm will function. All other alarms will remain inactive until the System is out of the Calibration Mode.

Operator settable alarms, as well as the rest of the System are dependent upon proper calibration. The Calibration Mode is entered only when the System requires calibration.

GREER COMPANY

Crane Systems

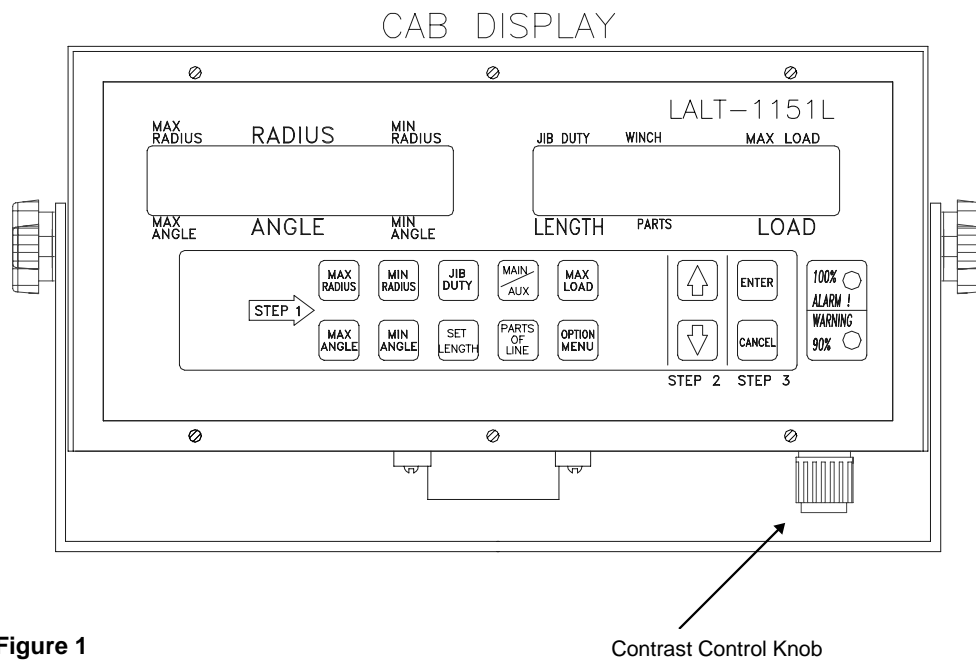

Figure 1

GREER COMPANY

Crane Systems

Calibration

After installation, the LALT™-1151L System for Lattice Cranes must be calibrated before it can operate.

- If the LALT™-1151L System **has never been calibrated**, complete Sections A–I for single winch cranes and Sections A–L for dual winch cranes. Always calibrate the System in the order shown in the following pages.
- If the LALT™-1151L System **has already been calibrated**, but needs recalibration in a particular area, check the Boom Length and Parts of Line (Sections B & C) for accuracy; then enter the Calibration Mode (Section D).
Next recalibrate only those areas requiring change. **DO NOT** perform initialization steps in Section A; *to do so will cause all previously stored calibration data to be lost.*

Note: If the displays are blank or all black, adjust the contrast knob (Fig.1) on the bottom of the Display Unit.

Required Tools

- Tape measure
- Inclinator (for measuring the angle of the boom)
- A test weight for each hoist that is heavy enough to make a single part line pull at least equal to 50% of the hoist rope maximum capacity. (See example for calculating the correct test weight on page 11.)

A Initialization

Perform the following "**INITIALIZATION**" steps 1-7 **ONLY** when calibrating the **ENTIRE** LALT™-1151L System. These steps **will remove all data that was previously stored in the System memory.**

GREER COMPANY

Crane Systems

1. Press **OPTION MENU**. The display will read: "SET RIGGING MODE."
2. Press **MIN RAD**.
3. Press **MIN ANG**.
4. Press **MAX ANG**.
5. Press **PARTS OF LINE**.
6. Press either **ENTER** for "YES" or **CANCEL** for "NO."
7. Press **CANCEL** to exit the **OPTION** menu.
Ensure that all limit displays **except** MAX LOAD show "____."

B Boom Length

Always set "BOOM LENGTH" before entering the Calibration Mode.

1. Press **SET LENGTH**.
2. Pressing the **↑** and **↓** arrows, set **BOOM LENGTH**.
3. Press **ENTER**.

C Parts of Line

Always set "PARTS OF LINE" before entering the Calibration Mode.

1. Press **MAIN/AUX** until the display reads: "**M**" (MAIN).
2. Press **PARTS OF LINE**.
3. Pressing the **↑** and **↓** arrows, set the **PARTS OF LINE** for the MAIN winch.
4. Press **ENTER**.

GREER COMPANY

Crane Systems

5. Verify that the **PARTS OF LINE** are correct on the display.
(If there is no auxiliary hoist line in use, do not complete steps 6-10.)
6. Press **MAIN/AUX** once; the display will read: "**A**" (AUXILIARY).
7. Press **PARTS OF LINE**.
8. Pressing the **↑** and **↓** arrows, set the Parts of Line for the AUXILIARY winch.
9. Press **ENTER**.
10. Verify that the **PARTS OF LINE** are correct on the display.

D Entering and Exiting the Calibration Mode

To calibrate the System, it is necessary to first enter the "CALIBRATION MODE."

1. Press **OPTION MENU**. The display will read: "SET RIGGING MODE."
2. Press the **↑** arrow three times. The display will read: "ENTER CAL. MODE."
3. Press **ENTER**. The display will read: "ENTER KEY CODE."
4. Press **MAX ANGLE** twice; then, press **OPTION MENU** three times. An asterisk will appear for each key press.
5. When the display reads: "CAL. ANGLE," the System is in the **CALIBRATION MODE**.
6. When ready to exit the **CALIBRATION MODE**, press **CANCEL** after completing any of the calibration routines.

GREER COMPANY

Crane Systems

E **Number Entry**

When entering angle, length, radius, or load numbers, a decimal should show on the screen.

- a) An *ANGLE* is displayed in degrees, decimal, and tenths of degree.

EXAMPLE: Ten and one half degrees = 10.5°

- b) *LENGTH*, *RADIUS*, and *SWING OFFSET* is displayed in feet, decimal, and tenths of feet.

EXAMPLE: Ten and one half feet = 10.5

- c) *LOAD* is displayed in pounds x 1000.

EXAMPLE: Ten thousand five hundred pounds = 10.5

GREER COMPANY

Crane Systems

F Boom Angle Calibration

The "**BOOM ANGLE**" is the angle measured between the boom centerline and horizontal.

When first entering "**CAL MODE**," the display will read: "CAL. ANGLE."

1. Press **ENTER** to start the routine.
2. Boom down (Fig. 2) to zero degrees.
Verify the angle with an inclinometer.
3. Press **ENTER**.
4. Boom up (Fig. 3) to at least 60 degrees.
Verify the angle with an inclinometer.
5. Press **ENTER**.
6. Pressing the **↑** and **↓** arrows,* set the **EXACT BOOM ANGLE**.
7. Press **ENTER**.
8. Press **ENTER** to exit the routine.

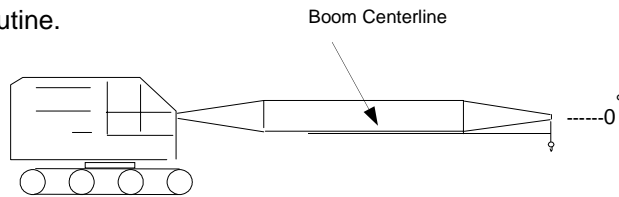

Figure 2

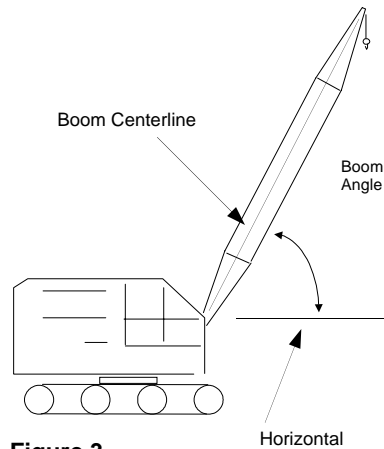

Figure 3

*The longer an **↑** or **↓** arrow is pressed, the faster the displayed numbers will change. When the arrow key is released, the flashing digit will be the digit that will change the next time an **↑** or **↓** arrow is pressed.

G Slew Offset Calibration

"**SLEW OFFSET**" is the horizontal distance between the centerline of rotation and the boom pivot. If the pivot pin is in front of the centerline of rotation, as illustrated, the slew offset must be entered as a **positive** number.

1. Press the **↑** arrow until the display reads: "CAL. SLEW OFFSET."
2. Press **ENTER** to start the routine.
3. Measure the horizontal distance on the crane between the centerline of rotation and the center of the boom pivot pin (Fig. 4) to get the *positive* SLEW OFFSET.
4. Pressing the **↑** arrow, set the **positive SLEW OFFSET**.
5. Press **ENTER**.
6. Press **ENTER** to exit the routine.

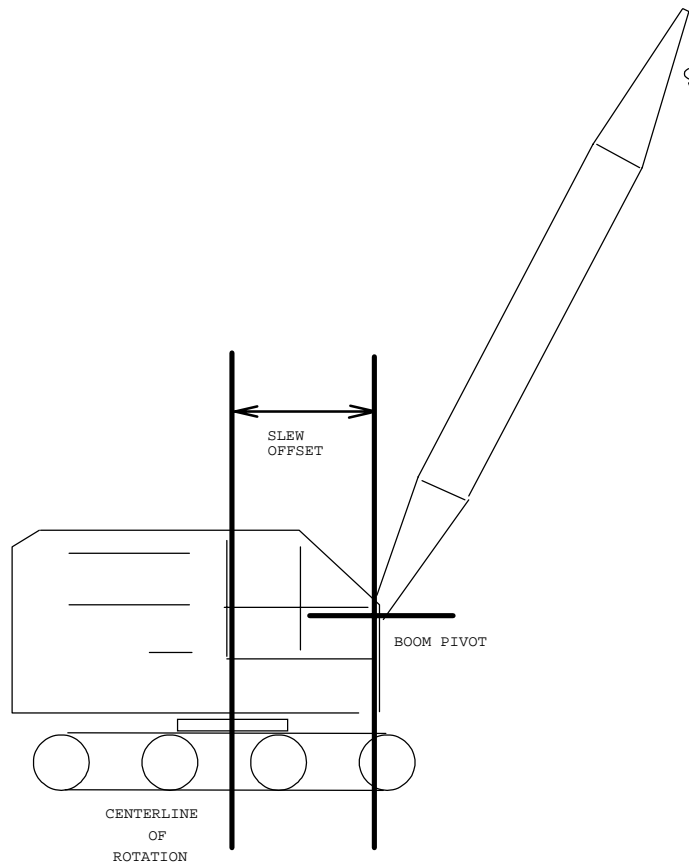





Figure 4

GREER COMPANY

Crane Systems

H Main Linepull Calibration

"**MAXIMUM MAIN LINEPULL**" is the maximum allowable tension in **one part** of the main winch hoist rope.

1. Press the  arrow until the display reads: "CAL. MAIN L-PULL."
2. Press **ENTER** to start the routine.
3. Pressing the  and  arrows, set the **MAXIMUM ALLOWABLE LINEPULL** of one part of the main winch hoist rope.
4. Press **ENTER**.
5. Verify that the value for the main linepull shown on the display is correct.
6. Press **ENTER** to exit the routine.

GREER COMPANY

Crane Systems

I Main Zero Calibration

"**MAIN ZERO**" is the tension in the main winch hoist rope when the hook is on the ground.

1. Press the **↑** arrow until the display reads: "CAL. MAIN ZERO."
2. Press **ENTER** to start the routine.
3. Put the main hook on the ground and let the lines go slack (Fig.5).
4. Press **ENTER**.
5. Press **ENTER** to exit the routine.

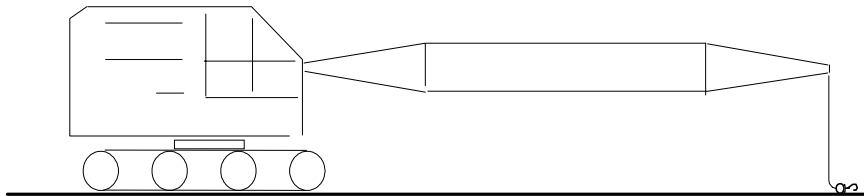

Figure 5

GREER COMPANY

Crane Systems

J Main Span Calibration

"**MAIN SPAN**" is the internal adjustment that causes the System to correctly indicate the main winch load weight.

1. Prepare to lift the *main winch test weight* at a safe radius (see capacity chart) for that load. Use a test weight that is heavy enough to make a single part line pull at least equal to 50% of the hoist rope maximum capacity.

Example for calculating test weight: A hoist rope with a 10,000 lb. capacity reeved to 4 parts of line, at 50% of the hoist rope maximum capacity will have a minimum test weight of 20,000 lbs. ($10,000 \times 4 \div 2 = 20,000$).

2. Press the **↑** arrow until the display reads: "CAL. MAIN SPAN."
3. Press **ENTER** to start the routine.
4. Pressing the **↑** and **↓** arrows, set the **TEST WEIGHT**.
5. Press **ENTER**.
6. Leaving the test weight on the ground, lift the rigging, letting it hang slack from the hook (Fig. 6).
7. Press **ENTER**.

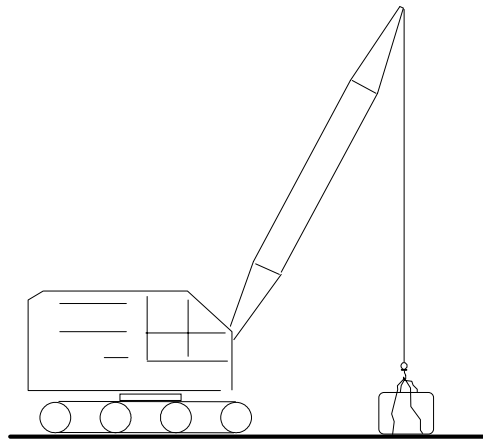

Figure 6

continued on next page

GREER COMPANY

Crane Systems

8. Lift the test weight off the ground (Fig. 7).
9. Press **ENTER**.
10. Verify that the load weight shown on the display is the test weight **plus** the weight of the rigging.
 - If the weight shown on the display is correct, press **ENTER** to exit the routine.
 - If the weight shown on the display is incorrect, press **ENTER** two times to reenter "**CAL MAIN SPAN**" and adjust the weight.

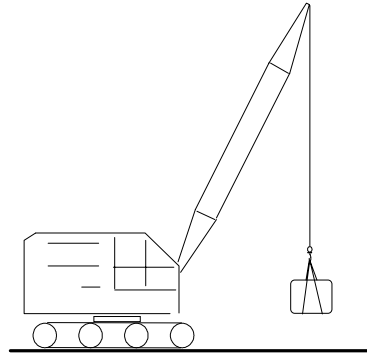

Figure 7

11. Continue with Option A or B, as appropriate:
 - A. If there is an auxiliary hoist winch in use on the crane, complete calibration steps in Sections J, K, and L.
 - B. If there is no auxiliary hoist winch in use on the crane, do **not** complete calibration steps in Sections J, K, and L. Press **CANCEL** to exit the **CALIBRATION MODE**.

GREER COMPANY

Crane Systems

κ **Aux. Linepull Calibration**

"**MAXIMUM AUX. LINEPULL**" is the maximum allowable tension in **one part** of the auxiliary winch hoist rope.

1. Press the **↑** arrow until the display reads: "CAL. AUX L-PULL."
2. Press **ENTER** to start the routine.
3. Pressing the **↑** and **↓** arrows, set the **MAXIMUM ALLOWABLE LINEPULL** of one part of the aux. winch hoist rope.
4. Press **ENTER**.
5. Verify that the value for the "AUX. L-PULL" shown on the display is correct.
6. Press **ENTER** to exit the routine.

GREER COMPANY

Crane Systems

L **Aux. Zero Calibration**

"**AUX. ZERO**" is the tension in the aux. winch hoist rope when the hook is on the ground.

1. Press the **↑** arrow until the display reads: "CAL. AUX. ZERO."
2. Press **ENTER** to start the routine.
3. Put the Aux. hook on the ground (Fig. 8), and let the lines go slack.
4. Press **ENTER**.
5. Press **ENTER** to exit the routine.

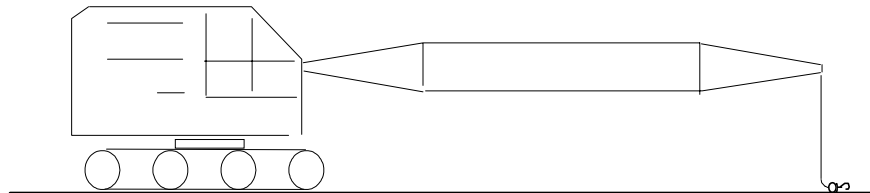

Figure 8

GREER COMPANY



Crane Systems

M **Aux. Span Calibration**

"**AUX. SPAN**" is the internal adjustment that causes the System to correctly indicate the weight of the auxiliary winch load.

1. Prepare to lift the *aux. winch test weight* at a safe radius (see capacity chart) for that load. Use a test weight that is heavy enough to make a single part line pull at least equal to 50% of the hoist rope maximum capacity.

Example for calculating test weight: A hoist rope with a 10,000 lb. capacity, reeved to 1 part of line, at 50% of the hoist rope maximum capacity will have a minimum test weight of 5,000 lbs. ($10,000 \times 1 \div 2 = 5,000$).

2. Press the  arrow until the display reads: "Cal. Aux. Span."
3. Press **ENTER** to start the routine.
4. Pressing the  and  arrows, set the **TEST WEIGHT**.
5. Press **ENTER**.

continued on next page.

1918 E. Glenwood Place, Santa Ana CA 92705 Tel: (714) 259-9702 Fax: (714) 259-7626 PN W310111 Rev A 12/01/00

GREER COMPANY

Crane Systems

6. Leaving the test weight on the ground, lift the rigging, letting it hang slack from the hook (Fig. 9).
7. Press **ENTER**.

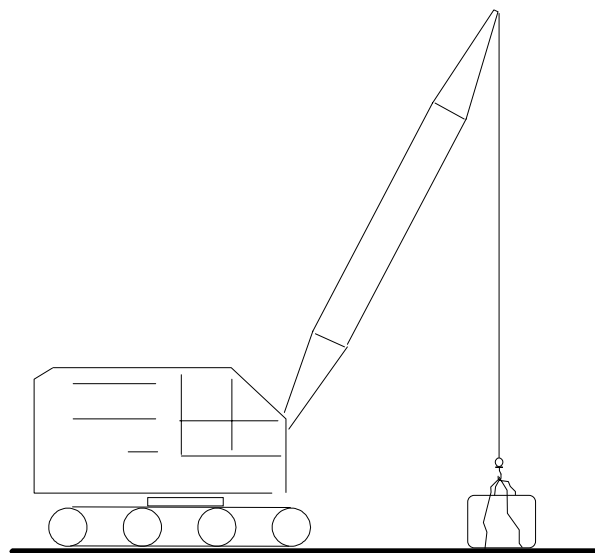

Figure 9

continued on next page.

GREER COMPANY

Crane Systems

8. Lift the test weight off the ground (Fig. 10).
9. Press **ENTER**.
10. Verify that the value shown on the display is the test weight **plus** the weight of the hook and rigging.
 - If the weight shown on the display is correct, press **ENTER** to exit the routine.
 - If the weight shown on the display is incorrect, press **ENTER** two (2) times to reenter **CAL. AUX. SPAN** and adjust the weight.
11. Press **CANCEL** to exit the **CALIBRATION MODE**.

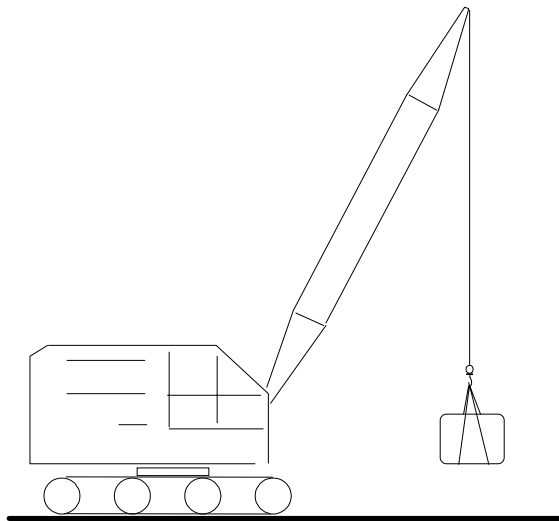

Figure 10

GREER COMPANY

Crane Systems

–For Service–
Call
GREER COMPANY
TELEPHONE: (714) 259-9702



1918 East Glenwood Place
Santa Ana, CA 92705
Telephone: (714) 259-9702
Fax: (714) 259-7626