

**BB™-508L/509L**  
**ANTI TWO-BLOCK ALARM SYSTEM**  
**LATTICE BOOM CRANES**

**INSTALLATION MANUAL**

**BB™-508L/509L ANTI TWO-BLOCK ALARM SYSTEM**  
**INSTALLATION AND TEST INSTRUCTIONS FOR LATTICE CRANES**  
**TABLE OF CONTENTS**

**SYSTEM DESCRIPTION** ..... 3-6

THE ALARM BOX ..... 3

MAIN ANTI TWO-BLOCK SWITCH - A250003..... 4

JIB ANTI TWO-BLOCK SWITCH - A250015 ..... 5

CABLES - A048075-22..... 6

CABLE STORAGE REEL - LATTICE - A240105..... 6

**INSTALLATION** ..... 7-12

BB™-508L/509L ALARM BOX..... 7

EXTENSION CABLE - A048000-XXX..... 8

MAIN ANTI TWO-BLOCK SWITCH - A250003..... 9-10

JIB ANTI TWO-BLOCK SWITCH - A250015 ..... 12

CHECKING THE ANTI TWO-BLOCK SYSTEM ..... 12

**TROUBLESHOOTING THE BB™-508L/509L SYSTEM** ..... 13

**ILLUSTRATIONS**

FIGURE 1. BB™-508L/509L LATTICE BOOM CRANE SYSTEM CABLING..... 3

FIGURE 2. BB™- THE MAIN ANTI TWO-BLOCK SWITCH - A250003..... 4

FIGURE 3. THE JIB ANTI TWO-BLOCK SWITCH - A250015 ..... 5

FIGURE 4. THE CABLE STORAGE REEL - LATTICE..... 6

FIGURE 5. BB™-508L/509L ALARM BOX INSTALLATION ..... 7

FIGURE 6. MAIN SWITCH - LEFT HAND MOUNT ..... 9

FIGURE 7. MAIN SWITCH - RIGHT HAND MOUNT..... 10

FIGURE 8: CHAIN & WEIGHT ASSEMBLY - A251000..... 11

## BB™-508L/509L ANTI TWO BLOCK ALARM SYSTEM

### SYSTEM DESCRIPTION

The BB™-508L/509L Anti Two-Block Alarm System for lattice cranes includes the BB™-508L Alarm Box, the main boom anti two-block sensor switch (A250003), the jib anti two-block sensor switch (A250015), and the extension/jib cables (A048000-XXX).

**Note:** In this manual, an "XXX" following part identification relates to "LENGTH IN FEET."

### THE ALARM BOX

Refer to Figure 1 below.

The BB™-508L/509L Alarm Box contains the fail-safe sensing circuit, a red alarm lamp, a horn, and the front panel controls. The controls include a **TEST** button that checks the internal circuitry and the **RIGGING** button. Pushing the **RIGGING** button during a two-block alarm will shut off the horn.

**Note:** The BB™-508L Alarm System is built for 12 VDC cranes. Order the BB™-509L Alarm System for 24 VDC cranes.

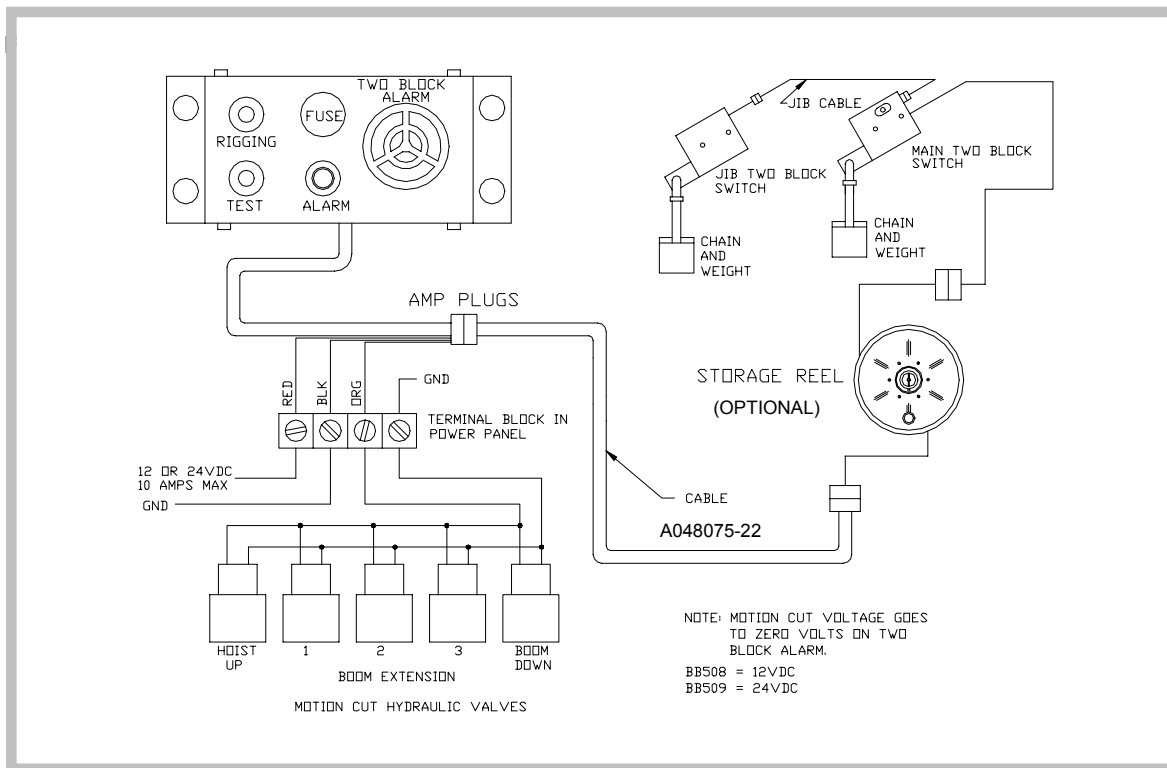
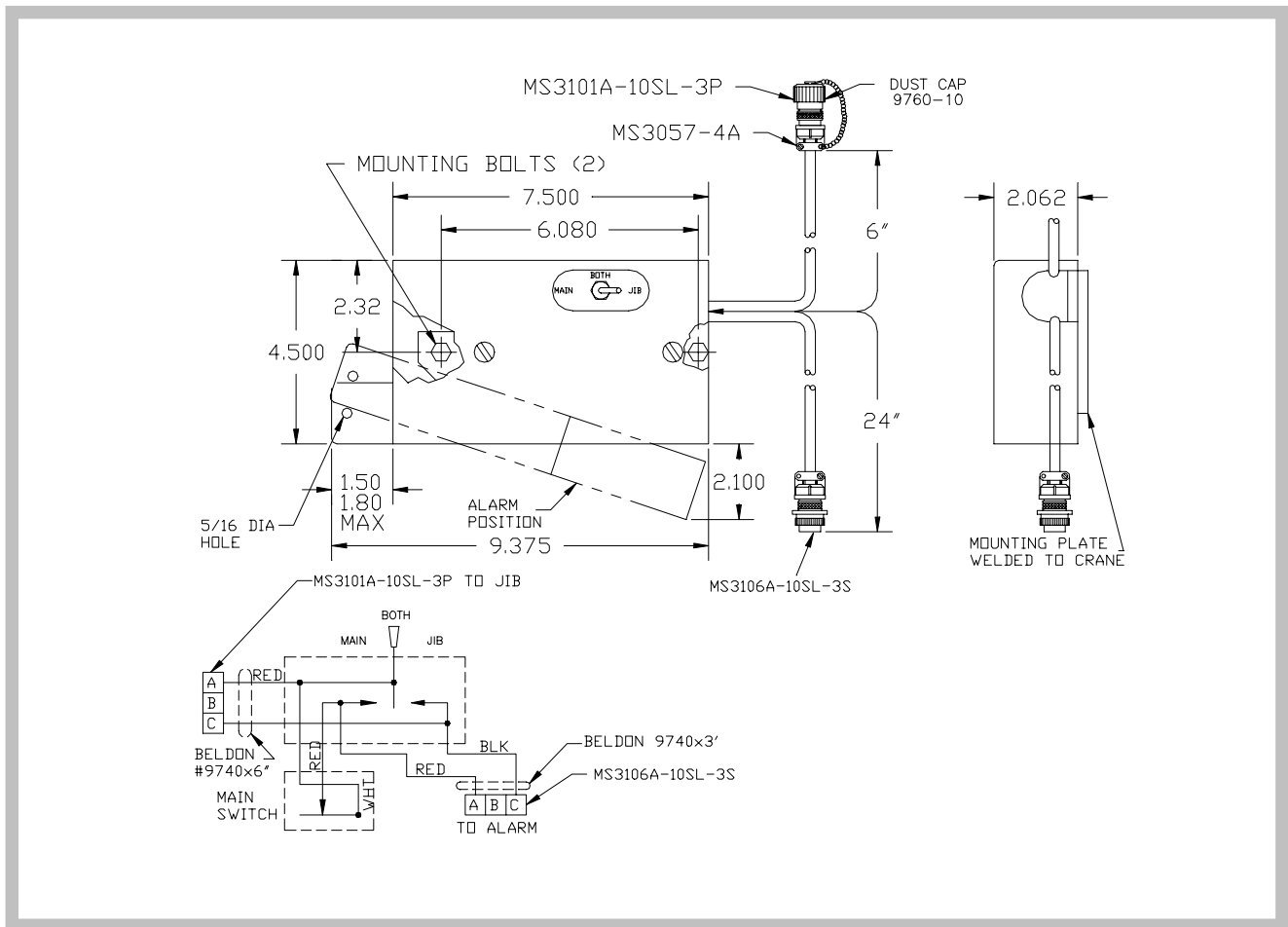

**FIGURE 1. BB™-508L/509L LATTICE BOOM CRANE SYSTEM CABLING**

**THE MAIN ANTI TWO-BLOCK SWITCH - A250003**

Refer to Figure 2 below. The main anti two-block switch (A250003) is mounted on the tip section of the main boom. If the selector switch is set on **MAIN**, the alarm activates when the main hoist line is two-blocked. If the selector switch is set on **BOTH**, the main or whip line on the jib can activate the alarm. When set on **JIB**, **ONLY** a whip line two-block will activate the alarm.

**Note:** Raising the block causes the weight to rise, which allows the arm of the switch to drop. This action creates an open circuit and activates the alarm.



**FIGURE 2. THE MAIN ANTI TWO-BLOCK SWITCH (A250003)**

**THE JIB ANTI TWO-BLOCK SWITCH - A250015**

Refer to Figure 3 below. The anti two-block jib switch (A250015) is mounted by the sheave at the tip of the jib. The electrical cable from the switch plugs into the receptacle on the BB™-508L/509L Alarm Box. The jib switch functions in the same way that the main switch functions.

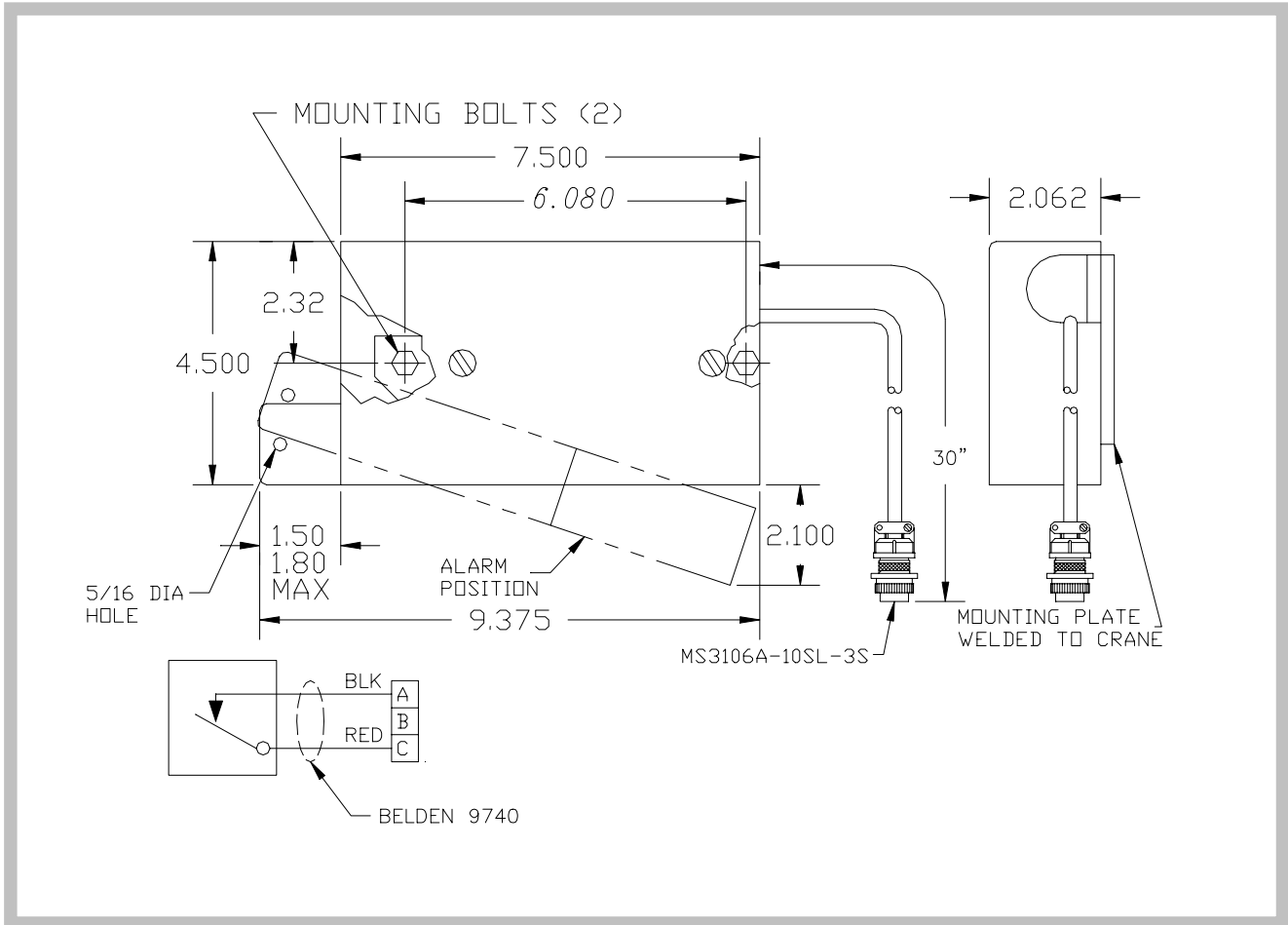

**FIGURE 3. THE JIB ANTI TWO-BLOCK SWITCH (A250015)**

## **CABLES**

Refer to Figure 1 on page 3.

A cable (A048075-22) connects to the alarm box cable jack in the electrical compartment and reaches to the boom foot hinge pin area. Extension cables (A048000-XXX) connect to it and to the main switch (A250003) at the boom head. The extension cables are usually made the same as max boom length and are wound up on a storage reel (A240105).

### **CABLE STORAGE REEL - LATTICE**

Refer to Figure 4 below. The cable storage reel (A240105) is a hand-cranked extension reel that can accommodate enough cable for maximum boom length. Excess loadcell or anti two-block cable for shorter boom lengths can be stored in this reel.

1. Clamp the cable storage reel to the lacing on the inside of the base section of the boom.  
**Note:** The hole pattern on the base of the reel will accommodate varying clamp sizes.
2. Tighten the wing-nut on the front of the extension reel. The wing-nut controls the rate of rotation of the reel.

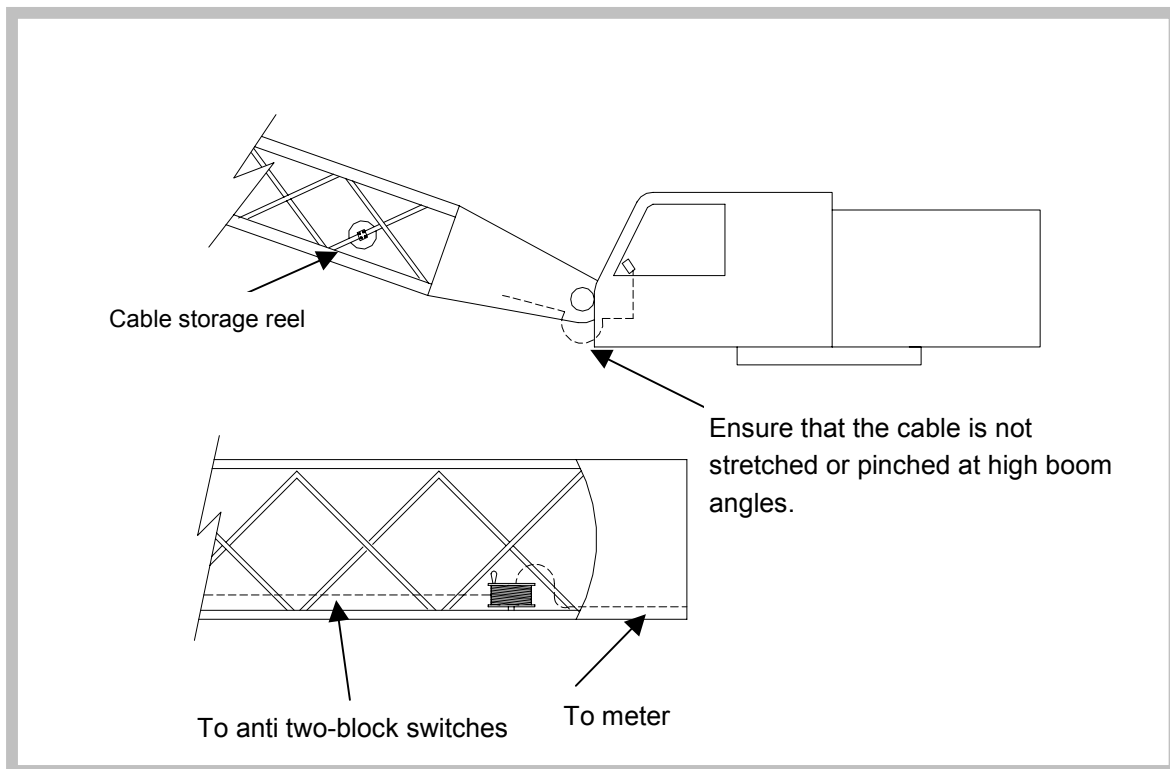

**FIGURE 4. THE CABLE STORAGE REEL - LATTICE**

## INSTALLATION

### THE BB™-508L/509L ALARM BOX

Refer to Figure 5 below. Mount the alarm box in the cab where it can be easily viewed and reached by the operator.

A small mounting bracket (supplied by the customer and long enough to bolt to both sides of the alarm box) is usually welded in the upper right or left corner of the cab near the windshield.

1. Route the cable to the electrical compartment (switched off by the ignition switch) and connect the red wire to plus 12 or 24 volts. Connect the black wire to the same ground used for other instruments.

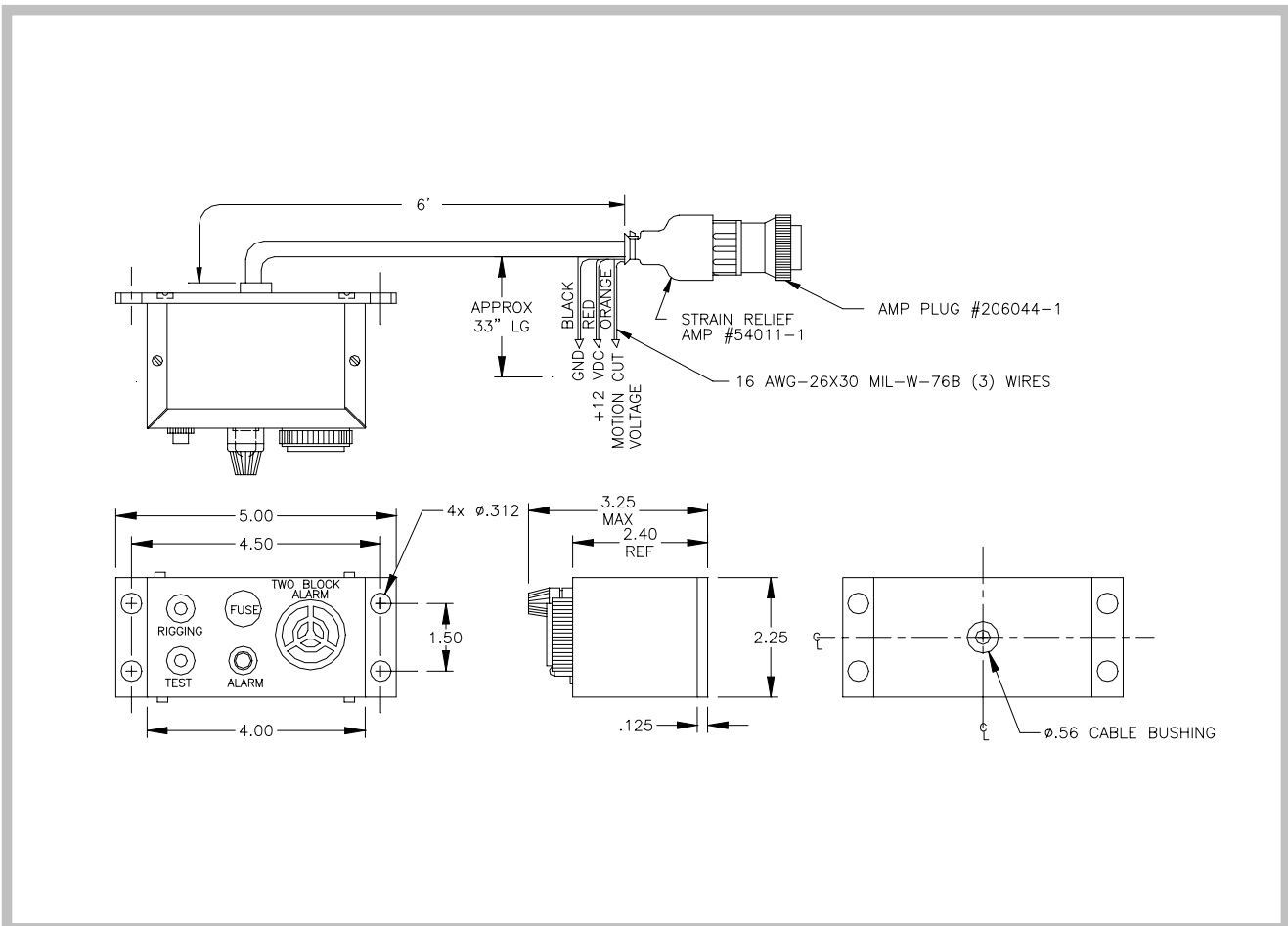

**FIGURE 5. BB™ 508L/509L ALARM BOX INSTALLATION**

## **THE EXTENSION CABLE - A048000-XXX (XXX = LENGTH IN FEET)**

Refer to Figure 1 on page 3.

1. Connect the (A048075-22) cable into the connector from the meter. Route the rest of the cable out to the boom base and anchor, as needed. Leave enough slack at the point where the cable goes from the superstructure to the boom near the pivot pin to prevent stretching or abrasion with full range boom movement. See Figure 4, page 6.
2. Next connect the free end of the cable to an extension cable (A048000-XXX) that is either on a storage reel or is a plain cable without a reel going out to the tip of the boom where it is connected to the ANTI TWO-BLOCK SWITCHES.
3. Strap the cable with plastic ty-wraps to the side of a lower chord up to the end. Dress the cable so it sticks out about 2 inches beyond the attachment fitting. This makes it easy to connect or disconnect the next extension when erecting or tearing down the boom.
4. Plug the (A048000-XXX) cable into the cable jack on the cable of the main switch (A250003). Connect aux or jib switches into the second cable on the main (A50003) switch and set.

## **MAIN ANTI TWO BLOCK SWITCH (A250003)**

### **SWITCH INSTALLATION**

Refer to Figure 2 (page 4) and Figures 6 and 7 (pages 9 & 10).

1. Remove the back weld plate from the switch assembly by removing the cover and two mounting bolts.
2. Mount the switch below the lower head sheave axle. Ensure that the mounting position will permit the switch to tilt down to 30° or 45° and that the cable from the swing arm will not drag on the boom head structure.
3. Weld on the plate and remount the switch with the two bolts.

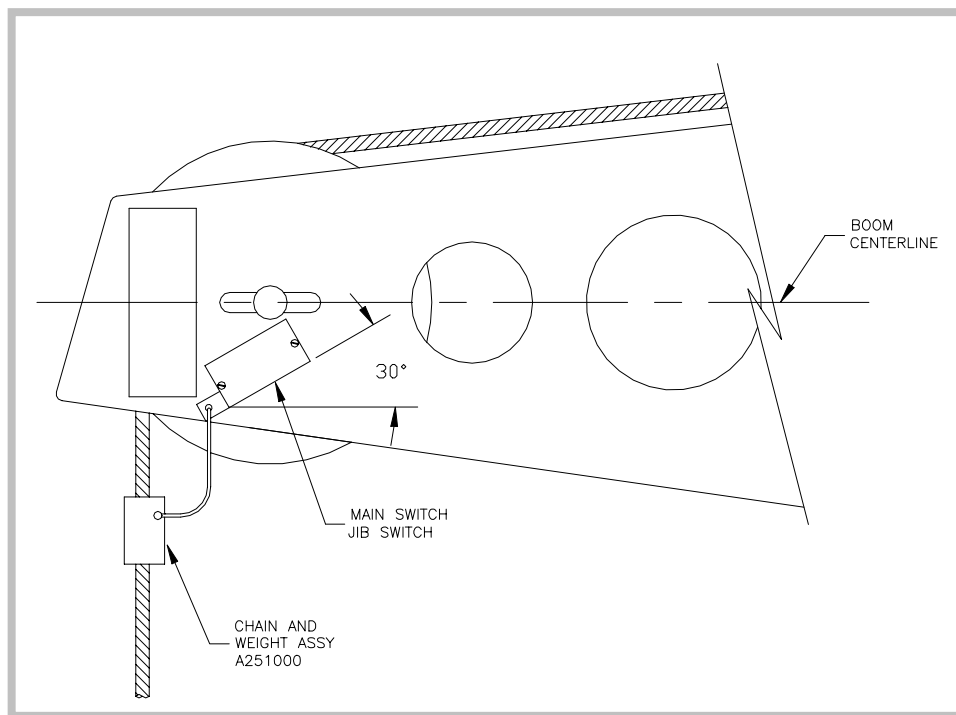

**FIGURE 6. MAIN SWITCH - LEFT-HAND MOUNT**

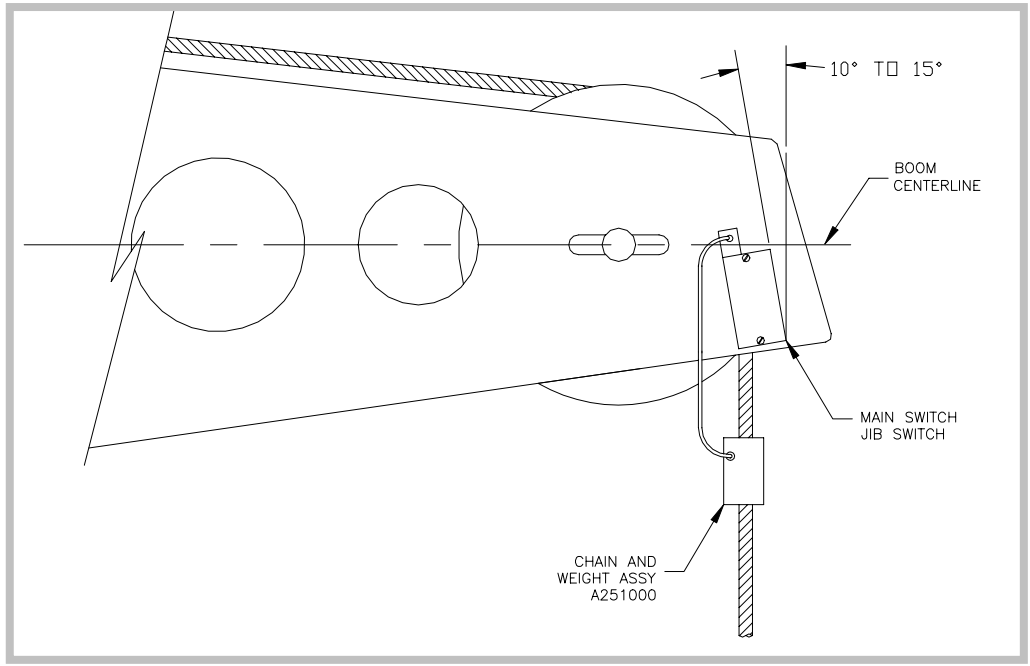

**FIGURE 7. MAIN SWITCH RIGHT-HAND MOUNT**

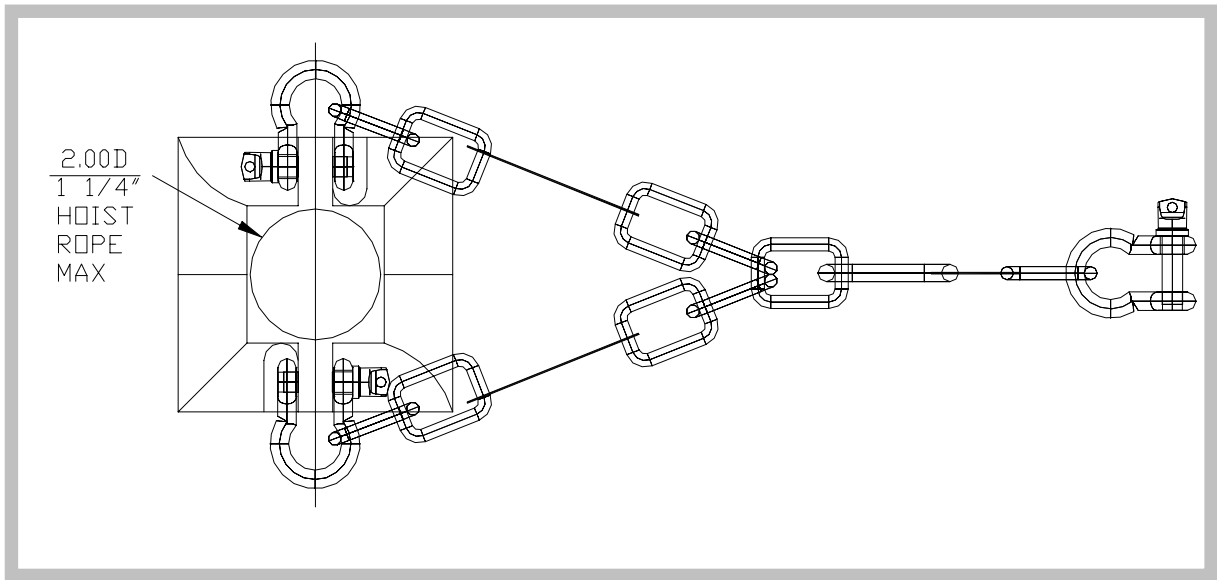

**FIGURE 8. CHAIN AND WEIGHT ASSEMBLY - A251000**

## **JIB SWITCH - A250015**

Refer to Figure 3 on page 5.

1. Mount the jib switch (A250015) at the jib head, as described on page 5.
2. Connect the jib extension cable (A048000xxx) to the jib switch.
3. Route the cable back along the inside of the chord on the same side as the main two-block switch.
4. Bring all of the slack back to the butt end so that there will be enough cable to reach to the receptacle on the main anti two-block switch (A250003).
5. Lace the cable inside the chord where a swinging ball cannot pinch it.

## **CHECKING THE ANTI TWO BLOCK SYSTEM**

1. Lower the boom so that the anti two-block switches can be reached.
2. Set the selector on the tip of the main switch to **MAIN**. With the selector in the **MAIN** position, only tripping the **MAIN** switch will cause a two-block alarm.
3. Set to **BOTH**. Either the **MAIN** or **JIB** switch will cause activation of the alarm.
4. Set to **JIB**. Only the **JIB** switch will cause the alarm to activate.
5. When the anti two-block system is in alarm, pressing the **RIGGING** switch will stop the horn, but the lamp will remain on.
6. When the system returns to normal following a two-block condition, the rigging lockout automatically resets; the horn will sound again at the next two-block condition.

## **TROUBLESHOOTING**

### **THE BB™-508L/509L ANTI TWO BLOCK SYSTEM FOR LATTICE CRANES**

Refer to Figure 1.

The BB™-508L System is out of alarm when it is getting a ground or continuity signal. The System goes into alarm when lifting the weight creates an open circuit. Fault 508 always indicates a two-block alarm.

#### **WITH THE SYSTEM CONNECTED, THE POWER ON, AND NO TWO-BLOCK CONDITION:**

1. Disconnect plugs 1 & 2.
2. Short pins 5 & 6 inside plug 1 together.
3. If the horn stops, the lamp goes off & the motion-cut releases, the BB™-508L is operating normally; if not, return BB™-508L/509L for repair.
4. Reconnect 1 & 2.
5. Disconnect plug 3 from 4.
6. Short terminals A & C in "3."
7. If BB™-508L/509L responds as in No. 3 above, the cable is OK and the problem is in the **MAIN** switch (A250003).
8. Connect an ohm meter (set at low scale) to pins A & C on "4."
9. With the weight down, the meter should show fewer than 10 ohms.
10. With the weight up, the meter should show **OPEN CIRCUIT**. With the meter on, check the 2 megohm & 20 megohm ranges.
11. If switch will not indicate 10 ohms, check that the toggle switch is on **MAIN**.  
If still in open circuit, check for broken wires in the switch, or return the switch for repair to the factory.

