

BB™508/509

**ANTI TWO-BLOCK ALARM SYSTEM
HYDRAULIC CRANE**

INSTALLATION



BB™-508/BB-509

ANTI TWO-BLOCK ALARM SYSTEM - HYDRAULIC CRANE

TABLE OF CONTENTS

BB™ 508/509 ANTI TWO-BLOCK ALARM SYSTEM – HYDRAULIC CRANE 3-9

 THE BB™ 508/509 ALARM BOX 5

 THE EXTENSION REEL ASSEMBLY 6

 THE MAIN SWITCH 7-9

INSTALLATION 10-14

 THE ALARM BOX 10

 THE EXTENSION REEL – HYDRAULIC..... 10-12

 REEL TO METER CABLE..... 12

 ANTI TWO-BLOCK SWITCH - JIB 12-13

 ANTI TWO-BLOCK SWITCH - ROOSTER/AUXILIARY 13

 JIB CABLE..... 13

 MOTION CUT VALVES..... 14

CHECKING THE ANTI TWO-BLOCK SYSTEM 15

TROUBLESHOOTING THE BB™-508/509 SYSTEM 16

FIGURES

FIGURE 1. THE BB™-508 ANTI TWO-BLOCK ALARM SYSTEM SET UP ON A HYDRAULIC CRANE 3

FIGURE 2. THE BB™-508/509 SYSTEM LAYOUT 4

FIGURE 3. THE BB™-508 ALARM BOX 5

FIGURE 4. THE EXTENSION REEL ASSEMBLY- BLR-783C..... 6

FIGURE 5. BOOM HEAD OR AUXILIARY ANTI TWO-BLOCK SWITCH - LEFT SIDE..... 7

FIGURE 6. MAIN SWITCH DETAIL..... 9

FIGURE 7. EXTENSION REEL – HYDRAULIC..... 11

FIGURE 8. EXAMPLE OF RIGHT SIDE MOUNT..... 13

FIGURE 9. MOTION CUTS - SYSTEM 14

FIGURE 10. MOTION CUTS - VALVE INSTALLATION..... 15

**BB™-508/BB-509
ANTI TWO-BLOCK ALARM SYSTEM – HYDRAULIC CRANE**

Refer to Figures 1 and 2. The BB™-508/509 Anti Two-Block Alarm System is used during the operation of a hydraulic crane to assist in avoiding a two-block condition. Model BB™-508 is built for 12 VDC cranes. Model BB™-509 is designed for cranes with 24 volt systems.

Model BB™-509 is designed for cranes with 24 volt systems.

SYSTEM COMPONENTS:

BB™-508 OR 509 ALARM BOX (METER)

Extension Reel Assembly – BLR-783C

**Main Sensor Switch with Selector
SW-258**

Cable from Reel to Alarm Box

Cable from Alarm Box to Power

OPTIONAL:

Auxiliary Switch with 5 ft. lead – SW-252

Jib Switch with 30 in. lead – SW-250

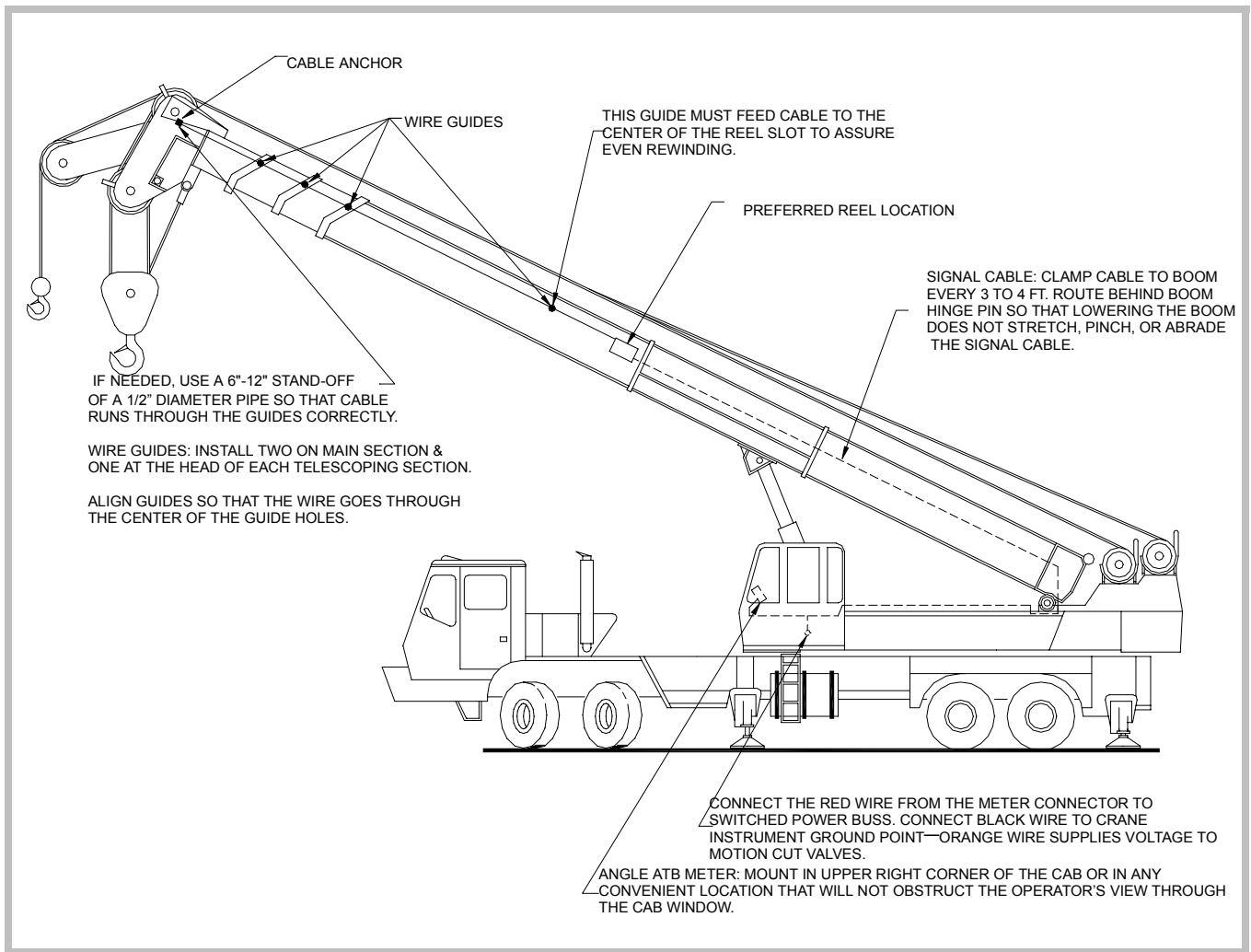

FIGURE 1: THE BB™ 508/509 ANTI TWO-BLOCK ALARM SYSTEM SET UP ON A HYDRAULIC CRANE

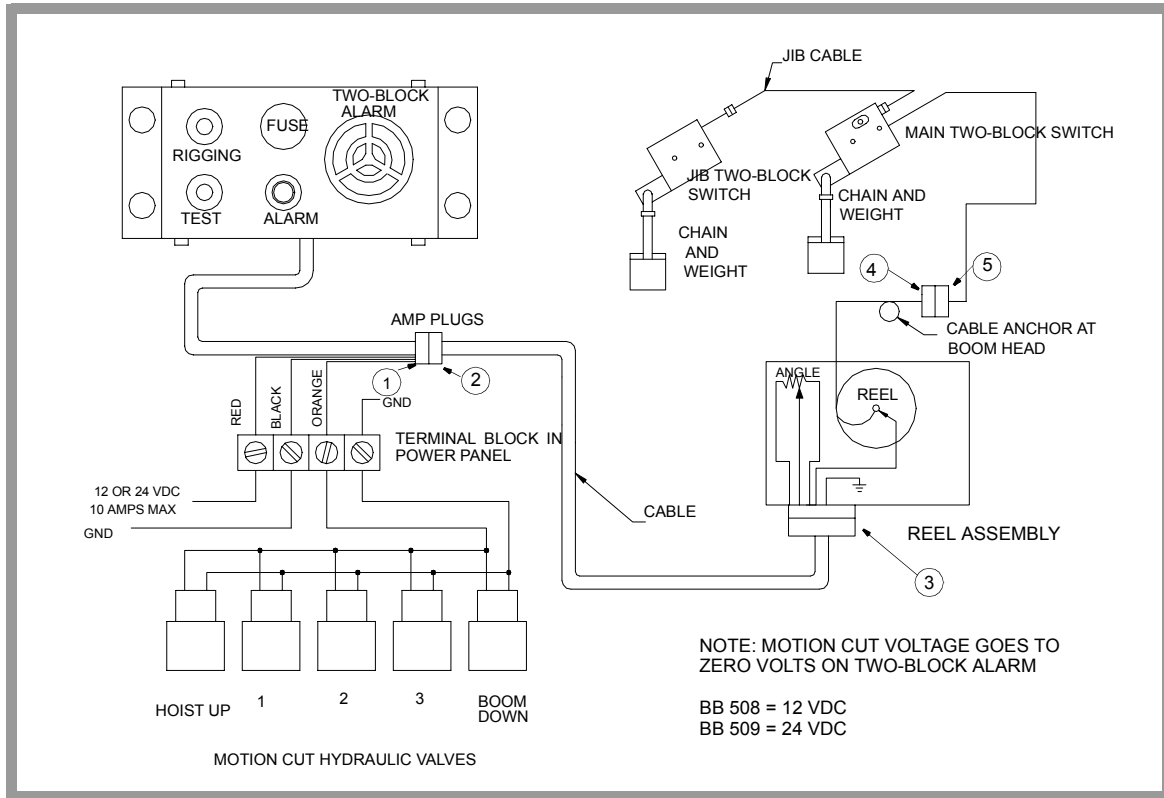

FIGURE 2: THE BB™ 508/509 SYSTEM LAYOUT

THE BB™-508/509 ALARM BOX

The BB™-508/509 Alarm Box, shown in Figure 3, contains the sensing circuit, 10 Amp relays to power motion cut valves, a red alarm lamp, a horn, and front panel controls. The TEST button checks the internal circuitry of the System. When the Two-Block alarm sounds activating the motion cut function, pressing the RIGGING button shuts off the horn and disables the motion cut function. The RIGGING MODE option is used when transporting the crane from one location to another or when shutting off the horn and motion cut function is desired. A cable running between the alarm box and the crane power connection carries the voltage for motion cut when the two-block alarm is activated.

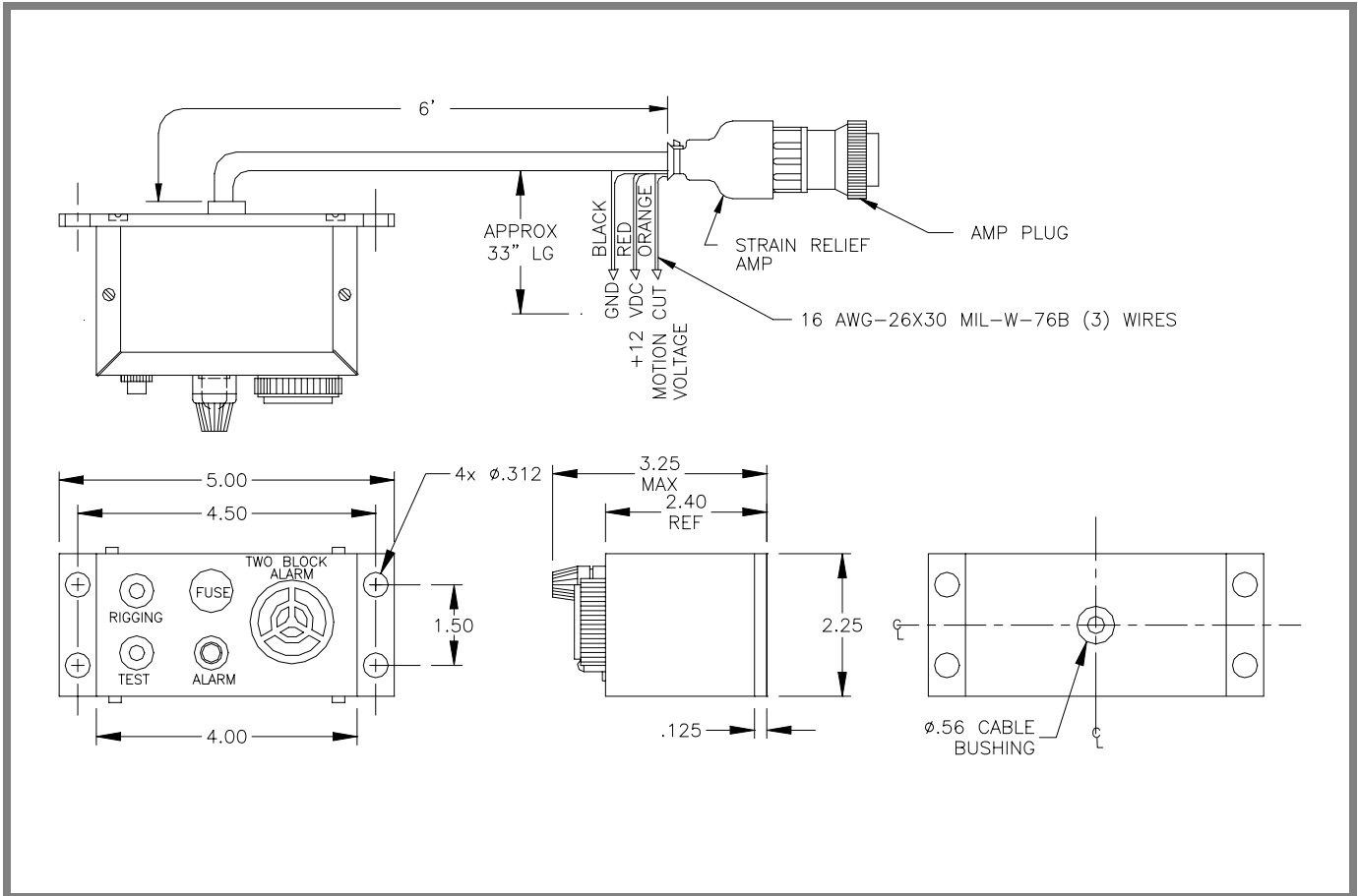

FIGURE 3: THE BB™ 508/509 ALARM BOX

THE EXTENSION REEL ASSEMBLY

The BLR-783C Extension Reel Assembly, shown in Figure 4, contains an insulated stainless steel 2-conductor cable wound onto a spring retracting reel. The cable carries the anti two-block signal from the switch to the Extension Reel and then to the Alarm Box. For Extension Reel installation, refer to page 10.

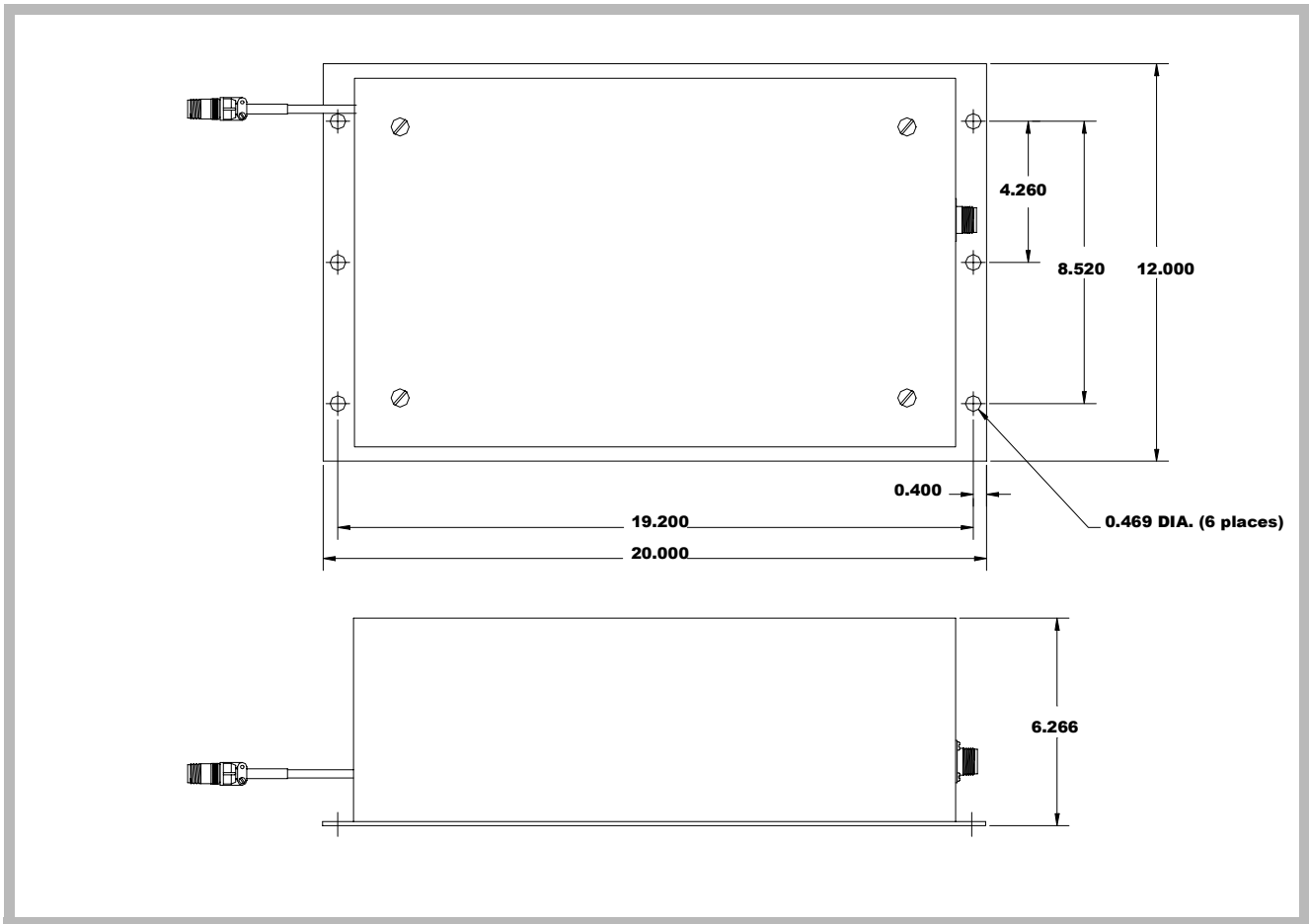

FIGURE 4: THE EXTENSION REEL ASSEMBLY – BLR-783C

THE MAIN SWITCH

The Main Switch with selector, shown in Figure 5, is mounted on the tip section of the main boom. When the selector switch is set on MAIN, the alarm sounds only when the main hoist line is two-blocked. When the selector switch is set on BOTH, either the main or whip line on the jib can cause the alarm to activate. When set on JIB ONLY, the whip line two-block alarm activates.

When the hook-block is raised high enough to make contact with the weight, the arm of the switch drops creating an open circuit and audible and visual alarms activate.

WARNING: All crane motions (hoist up, boom down, and extend out) will cease only if the crane has been fitted with the appropriate motion cutouts. If not sure that motion cutouts have been fitted to your crane, check with your Greer representative.

MOUNTING THE ANTI TWO-BLOCK SWITCH – MAIN

The mounting method used for installing the Main Anti Two-Block switch is dependent on the identification number on the switch arm. Follow the steps on the next page and refer to Figure 5 below.

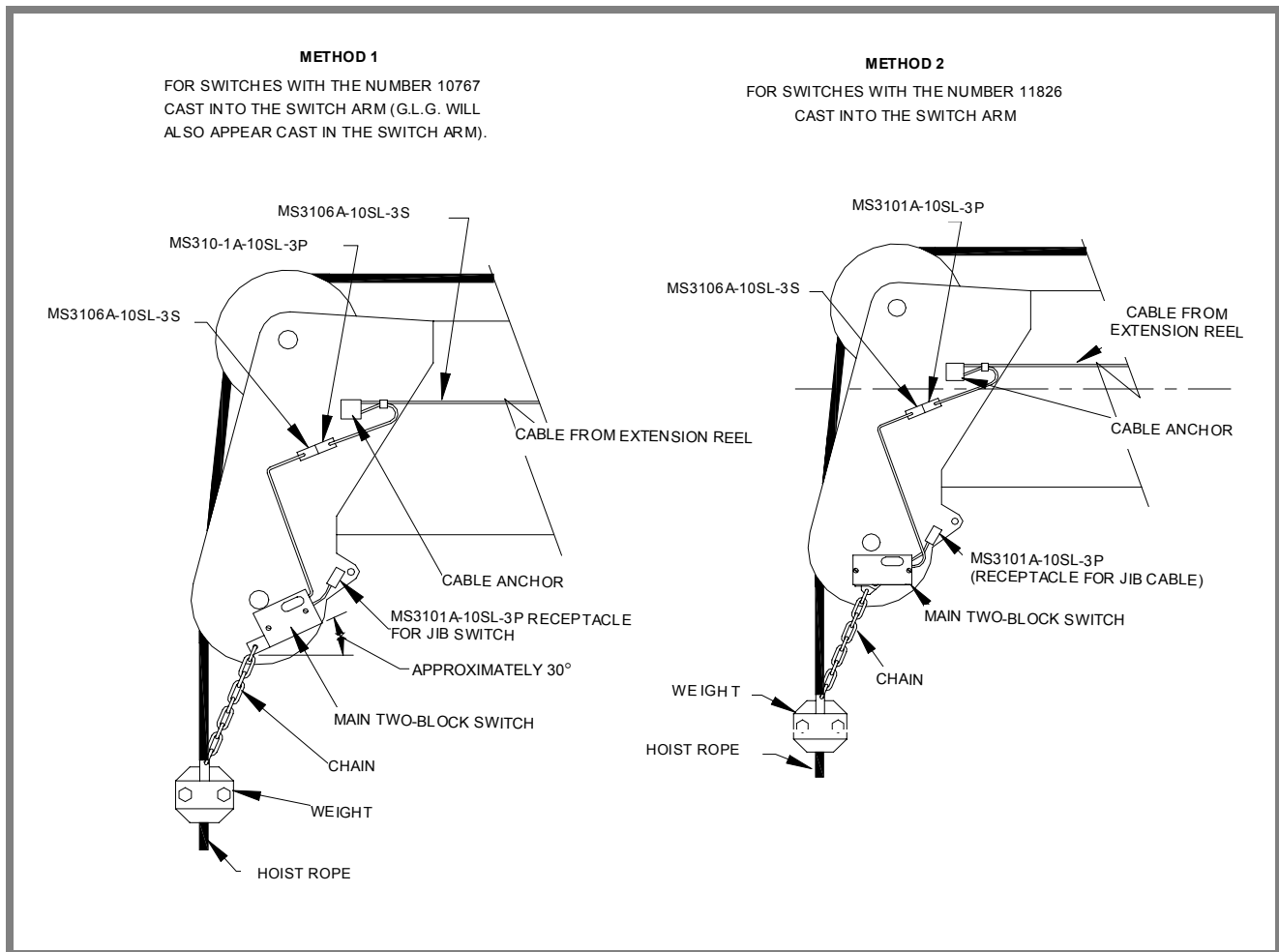

FIGURE 5: BOOM HEAD OR AUXILIARY ANTI TWO-BLOCK SWITCH LEFT SIDE

THE MAIN SWITCH IDENTIFICATION NUMBER

1. REMOVE THE TWO 1/4 – 20" TRUSS HEAD SCREWS FROM THE MAIN ANTI TWO-BLOCK SWITCH COVER AND SET COVER ASIDE.
2. LOOK AT THE PIVOTING SWITCH-ARM.
 - IF THE ARM IS CAST WITH THE NUMBER 10767, USE METHOD 1 (THE ARM WILL ALSO HAVE A G.L.G. CAST INTO IT).
 - IF THE ARM IS CAST WITH THE NUMBER 11826, USE METHOD 2.

MOUNTING METHODS

METHOD 1

- 1 LOWER THE BOOM TO ZERO DEGREES.
2. FIND AND MARK A LOCATION ON THE BOOM HEAD WHERE THE ANTI TWO-BLOCK SWITCH CAN BE MOUNTED AT ABOUT A 30° ANGLE TO THE BOOM.

NOTE: THE ANGLE IS MEASURED FROM THE BOTTOM FRONT EDGE OF THE SWITCH.

NOTE: ENSURE THAT THE SWITCH WILL NOT INTERFERE WITH ANY OF THE ATTACHMENTS WHEN FITTED.

3. REMOVE THE BACK WELD PLATE FROM THE SWITCH
4. WELD THE PLATE TO THE BOOM.
5. ALLOW PLATE TO COOL; THEN CLEAN AND PAINT THE PLATE.
6. MOUNT THE SWITCH TO THE PLATE AND REPLACE THE COVER.
7. ATTACH THE CHAIN AND WEIGHT ASSEMBLY TO THE SWITCH SWING-ARM.
8. CONNECT TO EXTENSION REEL CABLE ANCHORED AT THE TIP.

METHOD 2

1. LOWER THE BOOM TO ZERO DEGREES.
2. FIND AND MARK A LOCATION ON THE BOOM HEAD WHERE THE ANTI TWO-BLOCK SWITCH CAN BE MOUNTED PARALLEL TO THE BOOM.

NOTE: ENSURE THAT THE SWITCH WILL NOT INTERFERE WITH ANY OF THE ATTACHMENTS WHEN FITTED.

3. REMOVE THE BACK WELD PLATE FROM THE ANTI TWO-BLOCK SWITCH.
4. WELD THE PLATE TO THE BOOM.
5. ALLOW PLATE TO COOL; THEN CLEAN AND PAINT THE PLATE.

6. MOUNT THE ANTI TWO-BLOCK SWITCH TO THE PLATE; REPLACE THE COVER.
7. ATTACH THE CHAIN AND WEIGHT ASSEMBLY TO THE SWITCH SWING-ARM.
8. CONNECT TO EXTENSION REEL CABLE ANCHORED AT THE TIP.

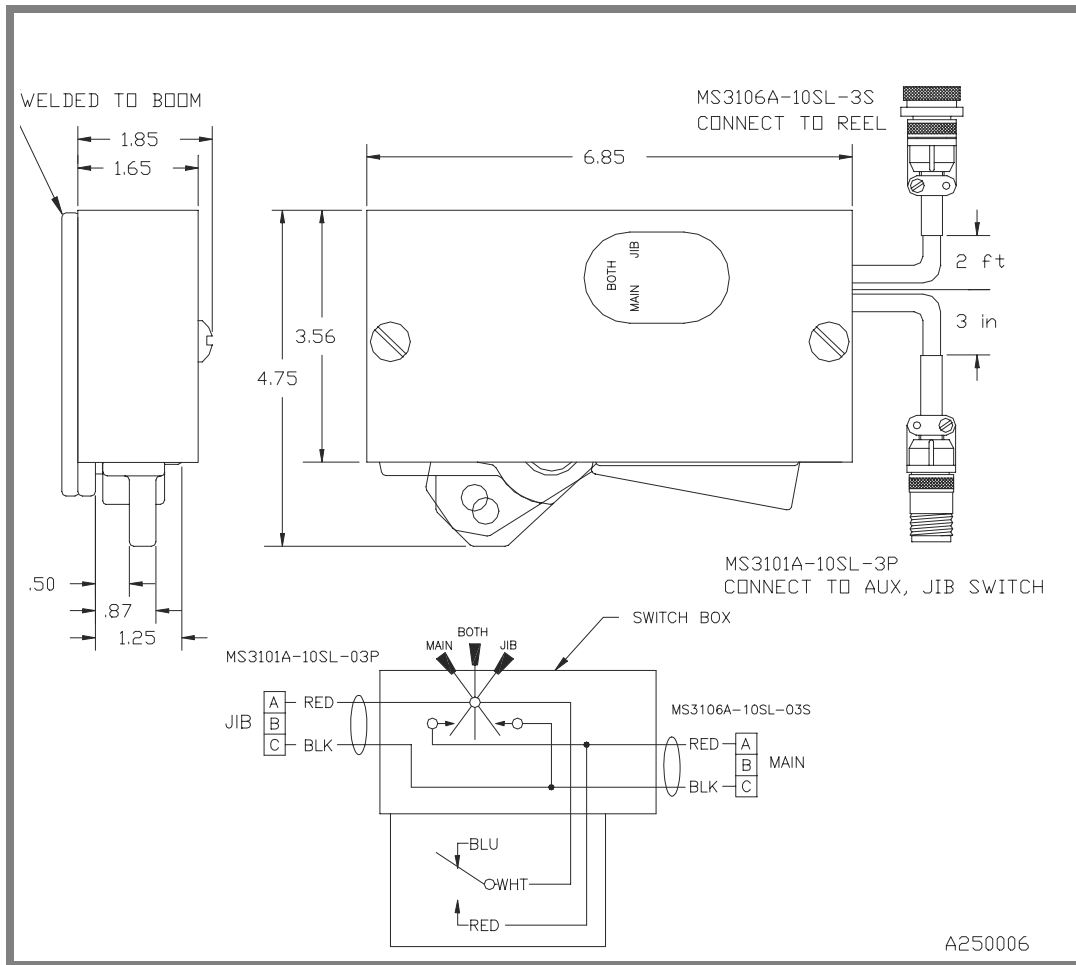

FIGURE 6: MAIN SWITCH DETAIL

INSTALLATION

THE ALARM BOX

REFER TO FIGURE 3, PAGE 5.

1. OBTAIN AND WELD A SMALL BRACKET (LONG ENOUGH TO BOLT TO BOTH SIDES OF THE ALARM BOX) IN THE UPPER RIGHT HAND CORNER OF THE CAB NEAR THE WINDSHIELD. (THE ALARM BOX MUST BE MOUNTED IN THE CAB WHERE IT IS EASILY VIEWED AND REACHED BY THE OPERATOR.)
2. REFER TO FIGURE 2. CONNECT THE RED WIRE TO PLUS 12 OR 24 VOLTS.
NOTE: THIS CONNECTION CAN BE SWITCHED ON AND OFF BY THE IGNITION SWITCH.
3. CONNECT THE BLACK WIRE TO THE SAME GROUND USED FOR OTHER INSTRUMENTS.
4. THE ORANGE WIRE SUPPLIES VOLTAGE TO THE MOTION CUT VALVES. IF MOTION CUT VALVES ARE NOT USED, COIL AND TIE THE ORANGE WIRE AND TAPE OR COVER THE END SO THAT IT CANNOT SHORT OUT TO ANYTHING.

THE EXTENSION REEL – HYDRAULIC

REFER TO FIGURE 7 ON THE NEXT PAGE.

THE EXTENSION REEL HAS 130 FT. OF SHIELDED 2-WIRE CABLE THAT TERMINATES IN A 3-PIN CONNECTOR. THIS CABLE **CANNOT** BE SHORTENED TO ACCOMMODATE VARYING BOOM LENGTHS.

1. FULLY RETRACT AND LOWER THE BOOM TO A HORIZONTAL POSITION.
2. SELECT A MOUNTING PLACE FOR THE EXTENSION REEL ON THE CAB SIDE OF THE NON-TELESCOPING BASE SECTION OF THE BOOM. THE EXTENSION REEL SHOULD BE PARALLEL TO THE BOOM AND FAR ENOUGH FORWARD TO AVOID OBSTRUCTION, E.G. THE CRANE CAB.
3. MOUNT THE EXTENSION REEL IN RELATION TO TIE-OFF POST (SEE FIGURE 9).
NOTE: USE 3/8 IN. DIAMETER BOLTS WELDED TO THE BOOM. IF THE BOOM IS NOT BOX SHAPED, LONGER BOLTS ARE REQUIRED ON THE TOP OR BOTTOM TO ENSURE THAT THE REEL REMAINS VERTICAL.
4. REMOVE THE FOUR ¼ IN. - 20 TRUSS HEAD SCREWS SECURING THE COVER OF THE EXTENSION REEL. REMOVE COVER AND SET SCREWS ASIDE.
5. REMOVE THE NYLON CORDS, BLOCKS, AND PACKING USED TO LOCK THE EXTENSION REEL DURING SHIPMENT.
6. UNCOIL THE CABLE AHEAD OF THE CABLE CLAMP, BUT DO NOT REMOVE THE CABLE CLAMP FROM THE EXTENSION REEL CABLE AT THIS TIME.

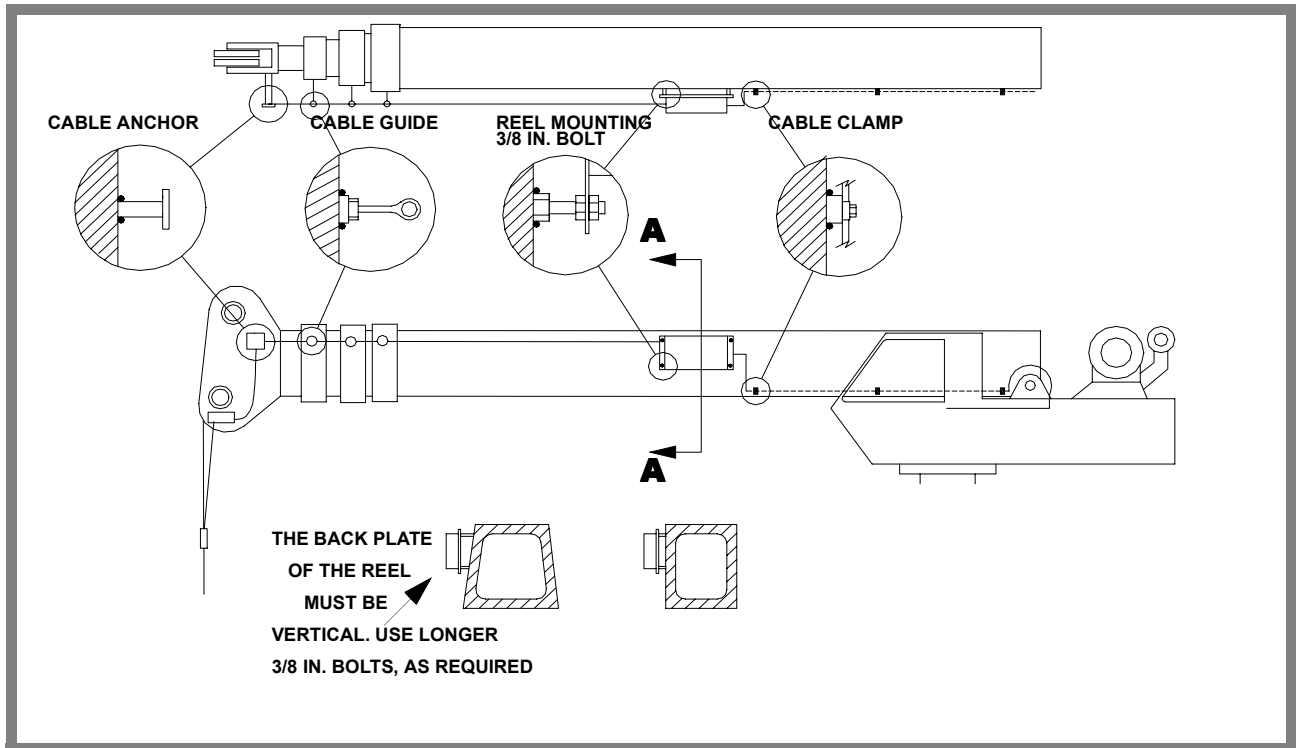

FIGURE 7: EXTENSION REEL (HYDRAULIC)

7. DETERMINE THE SITE FOR THE TIE-OFF POST ON THE BOOM HEAD, ENSURING THAT WHEN THE CABLE IS CLAMPED TO THE TIE-OFF POST, ONE CABLE GUIDE (EYE BOLT) AT THE END OF EACH BOOM SECTION WILL BE VISIBLE FROM THE TIE-OFF POST.
8. WELD THE TIE-OFF POST TO THE BOOM HEAD.
9. AFTER THE TIE-OFF POST COOLS, GRIP THE EXTENSION REEL CABLE FIRMLY AND PULL THE CABLE TO THE BOOM HEAD. TEMPORARILY ATTACH THE EXTENSION REEL CABLE TO THE TIE-OFF POST. ENSURE THAT THERE IS SOME TENSION IN THE CABLE.
10. INSTALL THE GUIDES, FORMING A STRAIGHT LINE FROM THE EXTENSION REEL TO THE TIE-OFF POST. ADJUST THE HEIGHT OF EACH GUIDE SO THAT THE CABLE WILL RUN THROUGH THE CENTER OF THE GUIDE HOLE. SMALL SQUARE WELD-BLOCKS AND JAM NUTS ARE PROVIDED.
11. WITH THE MAIN BOOM FULLY RETRACTED, GRIP THE EXTENSION REEL CABLE FIRMLY AND REMOVE THE CABLE FROM THE TIE-OFF POST; SLOWLY REWIND THE EXTENSION REEL CABLE ONTO THE EXTENSION REEL TO THE POINT OF NO TENSION.
12. CONTINUE TO REWIND THE EXTENSION REEL BY HAND UNTIL THE DISTANCE BETWEEN THE BOOM HEAD AND THE EXTENSION REEL CABLE CONNECTOR IS APPROXIMATELY 12 FT.

13. PULL THE EXTENSION REEL CABLE TOWARD THE BOOM HEAD THREADING IT THROUGH THE CABLE GUIDES.
14. SECURE THE CABLE TO THE TIE-OFF POST LEAVING 3 FT. OF CABLE BEYOND THE BOOM HEAD TIE-OFF POST FOR CONNECTION TO THE ANTI TWO-BLOCK SWITCH.
15. CAREFULLY ROUTE THE SIGNAL CABLE FROM THE EXTENSION REEL TO THE COMPUTER BEHIND THE BOOM PIVOT SO THAT LOWERING THE BOOM DOES NOT STRETCH, PINCH, OR ABRABE THE SIGNAL CABLE. ENSURE THAT THE CABLE IS CAREFULLY SECURED TO THE PATH.
16. WHEN THE CABLE IS PERMANENTLY ATTACHED AT THE BOOM HEAD, REMOVE THE REEL CABLE CLAMP. THE CLAMP MUST BE REMOVED BEFORE EXTENDING THE BOOM.
17. PULL THE CABLE OUT BY HAND A FOOT OR TWO TO CHECK THAT THE REEL IS OPERATING PROPERLY.

REEL TO METER CABLE

1. CONNECT THE CABLE PLUG TO THE REEL RECEPTACLE.
2. ROUTE AND CLAMP THE CABLE NEAR THE BOTTOM EDGE OF THE BOOM IN A PATH BEHIND THE BOOM HINGE AND AGAIN FORWARD INTO THE CAB AND ELECTRICAL COMPARTMENT AND THEN TO THE CONNECTOR ON THE METER CABLE. SMALL SQUARE WELD BLOCKS AND CABLE CLAMPS ARE PROVIDED.
3. ENSURE THE CABLE WILL NOT BE PULLED, PINCHED, OR ABRABED WHEN THE BOOM IS RAISED AND LOWERED.
4. COIL AND TIE ANY EXCESS CABLE IN A CONVENIENT OUT OF THE WAY LOCATION.

ANTI TWO-BLOCK SWITCH – JIB

THE MOUNTING METHOD USED DEPENDS ON THE MODEL NUMBER OF THE JIB ANTI TWO-BLOCK SWITCH.

1. REMOVE THE TWO 1/4-20 TRUSS HEAD SCREWS FROM THE ANTI TWO-BLOCK SWITCH COVER; SET COVER ASIDE.
 - IF THE PIVOTING SWITCH ARM IS CAST WITH THE NUMBER 10767, USE METHOD 1 (SEE PAGE 8).
 - IF THE ARM IS CAST WITH THE NUMBER 11826, USE METHOD 2 (SEE PAGE 8).

NOTE: THE ARM WILL ALSO HAVE A G.L.G. CAST INTO IT.

2. IN SOME CASES, THE ANTI TWO-BLOCK SWITCH WILL HAVE TO BE MOUNTED BEHIND THE JIB SHEAVE. THE JIB SWITCH IS CONNECTED TO THE MAIN ANTI TWO-BLOCK SWITCH WITH A CABLE.

NOTE: A SMALL LOOP, WHICH CAN BE COILED UP WHEN NOT IN USE, WILL BE REQUIRED TO

CONNECT THE CABLE TO THE MAIN SWITCH.

- a Connect the jib cable to the jib switch.
- b Lace the cable inside the jib where it cannot be pinched or damaged.
- c Secure the cable every 3 to 4 feet.
- d Connect jib cable to main switch and correct selector setting.

ANTI TWO-BLOCK SWITCH – ROOSTER/AUXILIARY

The rooster/auxiliary switch is installed the same way as the jib switch but in most cases the cable from the switch will be long enough to connect straight to the main Anti Two-Block switch. Clamp the cable to the boom head to prevent damage.

JIB CABLE

- 1. Plug the cable into the jib switch cable connector.
- 2. Lace the cable inside the jib structure where it can't be pinched by a swinging overhaul ball.
- 3. When the jib is installed, route the cable to the plug of the shorter of the two cables on the main switch.

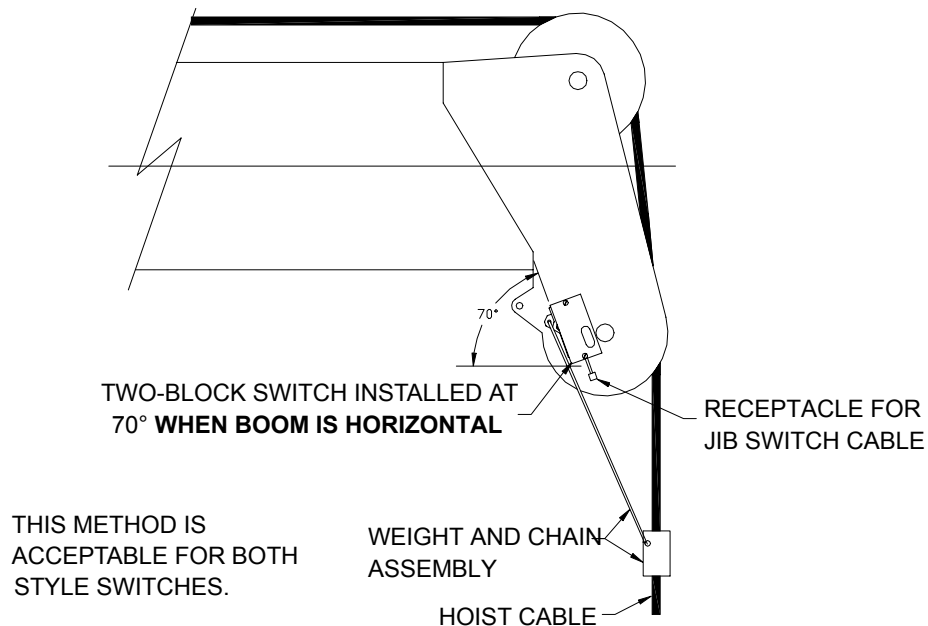

FIGURE 8: EXAMPLE OF RIGHT SIDE MOUNT

MOTION CUT VALVES

MOTION CUT - SINGLE SIGNAL

REFER TO FIGURE 9 BELOW AND FIGURE 10 ON THE NEXT PAGE.

THE SINGLE ORANGE WIRE CONTROLS THE MOTION CUT SIGNAL. WHEN NOT IN ALARM MODE, THE ALARM BOX ALLOWS THIS WIRE TO CARRY THE POSITIVE VOLTAGE OF THE CRANE WHICH IS 12 OR 24 VOLTS DC. WHEN AN ALARM OCCURS, THE POSITIVE VOLTAGE IS SHUT OFF.

THE ORANGE WIRE IS TO BE CONNECTED TO ALL CUTOFF MECHANISMS; THE OTHER TERMINAL OF ANY CUTOFF MECHANISM IS TO BE TIED TO THE CRANE "GROUND." THE MOTION CUT VALVES ON A HYDRAULIC CRANE MUST BE THE TYPE THAT OPEN WHEN THEIR SOLENOIDS ARE ENERGIZED. THEY SHOULD BE INSTALLED ON THE HYDRAULIC LINES FEEDING MAIN AND WHIP, HOIST UP, BOOM DOWN, AND TELESCOPE OUT LINES.

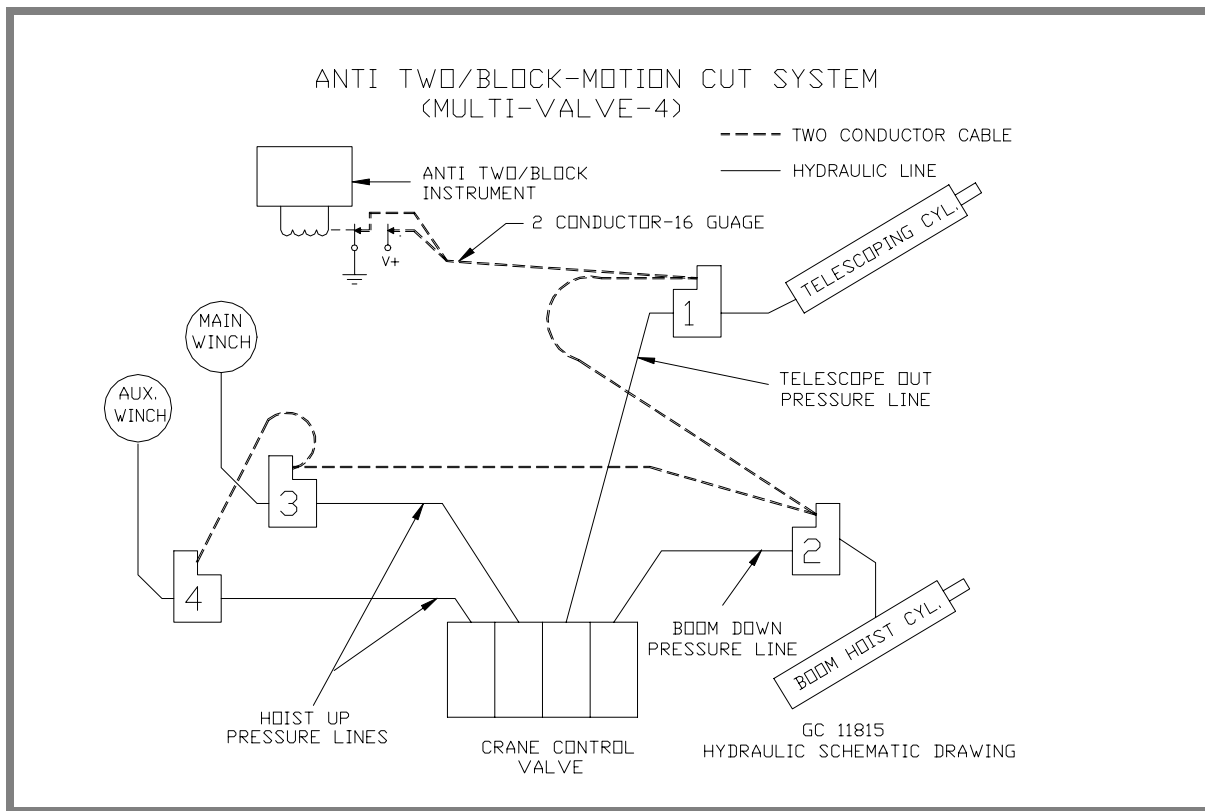

FIGURE 9: MOTION CUTS

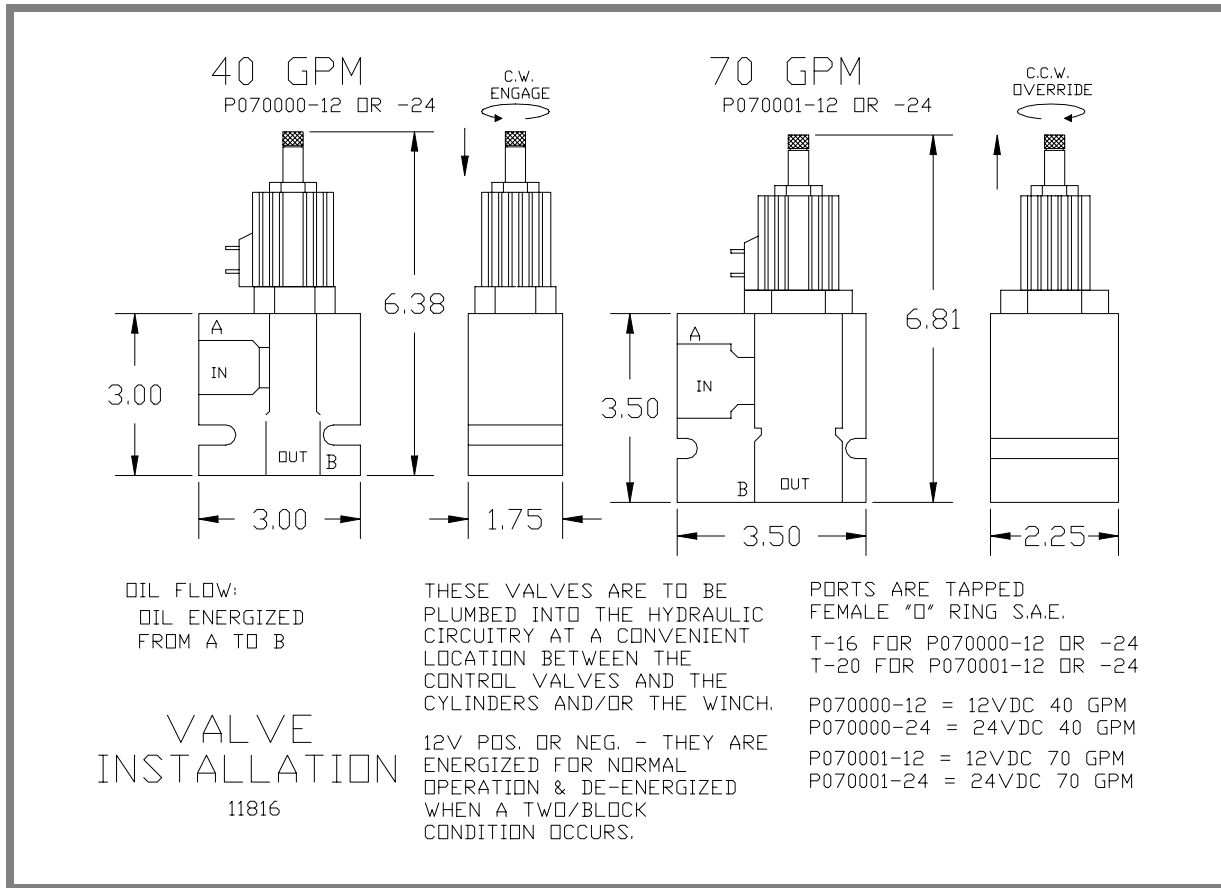

FIGURE 10: MOTION CUTS

CHECKING THE ANTI TWO-BLOCK SYSTEM

1. LOWER THE BOOM SO THAT THE ANTI TWO-BLOCK SWITCHES CAN BE REACHED.
2. SET THE SELECTOR SWITCH ON THE TOP OF THE MAIN SWITCH TO **MAIN**. WITH THE SELECTOR IN THIS POSITION, THE **MAIN SWITCH** MUST BE TRIPPED TO ACTIVATE THE ANTI TWO-BLOCK ALARM.
3. SET THE SELECTOR SWITCH TO **BOTH**. TRIPPING EITHER THE MAIN SWITCH OR THE JIB SWITCH WILL ACTIVATE THE ANTI TWO-BLOCK ALARM.
4. SET THE SELECTOR TO **JIB**. ONLY THE JIB SWITCH WILL ACTIVATE THE ANTI TWO-BLOCK ALARM.
5. WITH THE ANTI TWO-BLOCK SYSTEM IN THE ALARM MODE, PRESS THE RIGGING SWITCH. THIS ACTION STOPS THE HORN AND RESTORES MOTION TO THE BOOM BY DEACTIVATING THE MOTION CUTS. THE LAMP WILL CONTINUE STEADY.

WARNING: EACH TIME THE ANTI TWO-BLOCK ALARM SOUNDS, ENSURE THAT THE CORRECT CONTROLS LOCK.

TROUBLE SHOOTING THE BB™-508/BB-509

ANTI TWO-BLOCK SYSTEM

REFER TO FIGURE 2.

THE BB™-508 SYSTEM IS OUT OF ALARM WHEN IT IS GETTING A GROUND OR A CONTINUITY SIGNAL. THE SYSTEM GOES INTO ALARM WHEN LIFTING THE WEIGHT CREATES AN OPEN CIRCUIT.

WHEN THE SYSTEM IS CONNECTED & THE POWER IS ON BUT NOT IN TWO- BLOCK:

FAULT: 508 IS ALWAYS IN ALARM.

1. DISCONNECT PLUGS 1 & 2 (SHOWN IN FIGURE 2).
2. SHORT PIN 5 & 6 INSIDE PLUG 1 TOGETHER
IF HORN STOPS, LAMP GOES OFF, AND MOTION-CUT RELEASES, THE 508 IS OK.
IF NOT, RETURN 508 FOR REPAIR.
3. RECONNECT 1 & 2.
4. DISCONNECT PLUG 3 (SHOWN IN FIGURE 2).
5. IN PLUG 3, SHORT TERMINALS E & F TOGETHER.
IF 508 RESPONDS PER NUMBER 2 ABOVE, THE CABLE & 508 ARE OK.
IF NOT, CABLE HAS AN OPEN WIRE IN THE E OR F CIRCUIT.
6. RECONNECT "3" TO REEL.
7. SHORT THE REEL CABLE WIRES WHERE THEY CONNECT TO THE TERMINAL BLOCK ON THE SIDE OF THE REEL.
IF THE 508 RESPONDS PER NUMBER 2 ABOVE, THE REEL ALSO IS OK.
IF NOT, THERE IS AN OPEN CIRCUIT BETWEEN THE CABLE "SHORT" AND THE REEL RECEPTACLE.
8. DISCONNECT PLUGS 4 & 5 (SHOWN IN FIGURE 2) AT THE SWITCH.
9. SHORT TERMINALS A & C IN "4."
IF 508 RESPONDS PER NUMBER 2 ABOVE, THE CABLE IS OK;
THE TROUBLE IS IN THE SW-208 SWITCH.
10. CONNECT AN OHM METER (SET AT LOW SCALE) TO PINS A & C ON "5."
 - A) WITH THE WEIGHT DOWN, THE METER SHOULD SHOW UNDER 10 OHMS.
 - B) WITH THE WEIGHT UP, THE METER SHOULD SHOW OPEN CIRCUIT. CHECK WITH THE METER ON THE 2 MEGOHM AND 20 MEGOHM RANGES. IF THE SWITCH WILL NOT INDICATE 10 OHM, CHECK THAT THE TOGGLE SWITCH IS ON MAIN.
IF STILL IN OPEN CIRCUIT, CHECK FOR OPEN WIRES IN THE SWITCH, OR RETURN SWITCH FOR REPAIR TO FACTORY.

