

BA590/591

Angle indicator system™

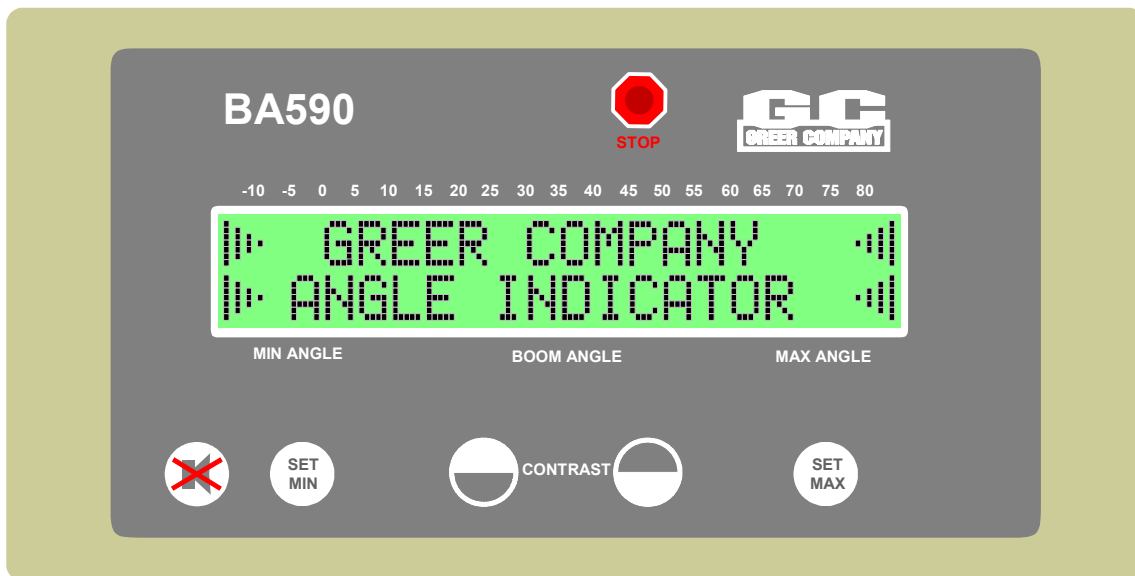

Operator's Manual



BA590/591 Angle indicator system™

Table of Contents

1. System overview	3
2. Powering up	4
3. What's on the display?	5-6
4. Adjusting the display contrast.....	7
5. Setting, removing, and adjusting angle alarm limits	8-9
6. Alarms and canceling the audible alarm.....	10
7. BA591 system installation	11
LMI system program chip.....	11
Indicator connection.....	11
8. BA590 system installation	12
System power cable connection	12
Angle sensor mounting	13-14
Angle sensor cable connection	15
9. Inspection & maintenance	16
BA591 system.....	16
BA590 system.....	16
10. Troubleshooting & servicing	17



The BA590/591 *Angle indicator system™* is designed to aid the fully trained and experienced crane operator in safe crane setup and operation involving boom angles. This manual provides the operator with instructions for using the BA590/591 system.

At no time may this system be used as a substitute for the standard safety practices and precautions required in the safe setup and operation of cranes.

1. System overview.

The BA590/591 *Angle indicator system*[™] is used during setup and operation of the crane to display the boom angle and to set and display boom angle limits. The system provides visual and audible warning alerts if the set limit(s) is (are) exceeded.

This manual provides operation, installation, setup, and troubleshooting information for both the BA 590 and 591 systems. The operation and use of the BA 590 or BA591 system is identical.

- The BA590 is a stand-alone system that includes an angle sensor.
- The BA591 is installed as part of a Greer LMI System.

The display shows the current working boom angle for the crane as a numeric value and as a moving bar meter. Two available alarm limits can be set by the operator: - a **high angle limit** (exhibited on the display as a left pointing arrow) and a **low angle limit** (exhibited on the display as a right pointing arrow).

- If the current working boom angle **exceeds** the set high angle limit, an alarm will sound.
- If the current working boom angle goes **below** the set low angle limit, the same alarm will sound.

These limits are shown numerically in the display boxes above the “MIN ANGLE” and “MAX ANGLE” labels and as an arrow on the top display line.

2. Powering up.

Upon system power-up, the display will show the message:

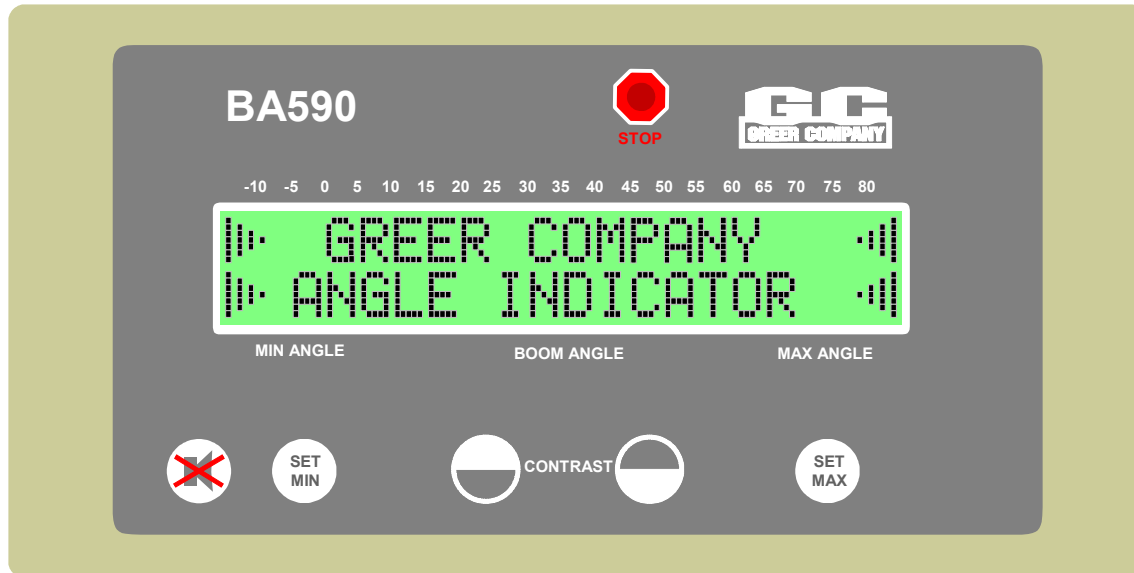

During this operation, the system audible alarm will sound and the red warning indicator lamp will be illuminated.

The complete power-up sequence takes around five seconds; once completed the system is ready for use.

3. What's on the display?

When the system is powered up and the startup sequence completed, the bottom line of the display will show the following information:

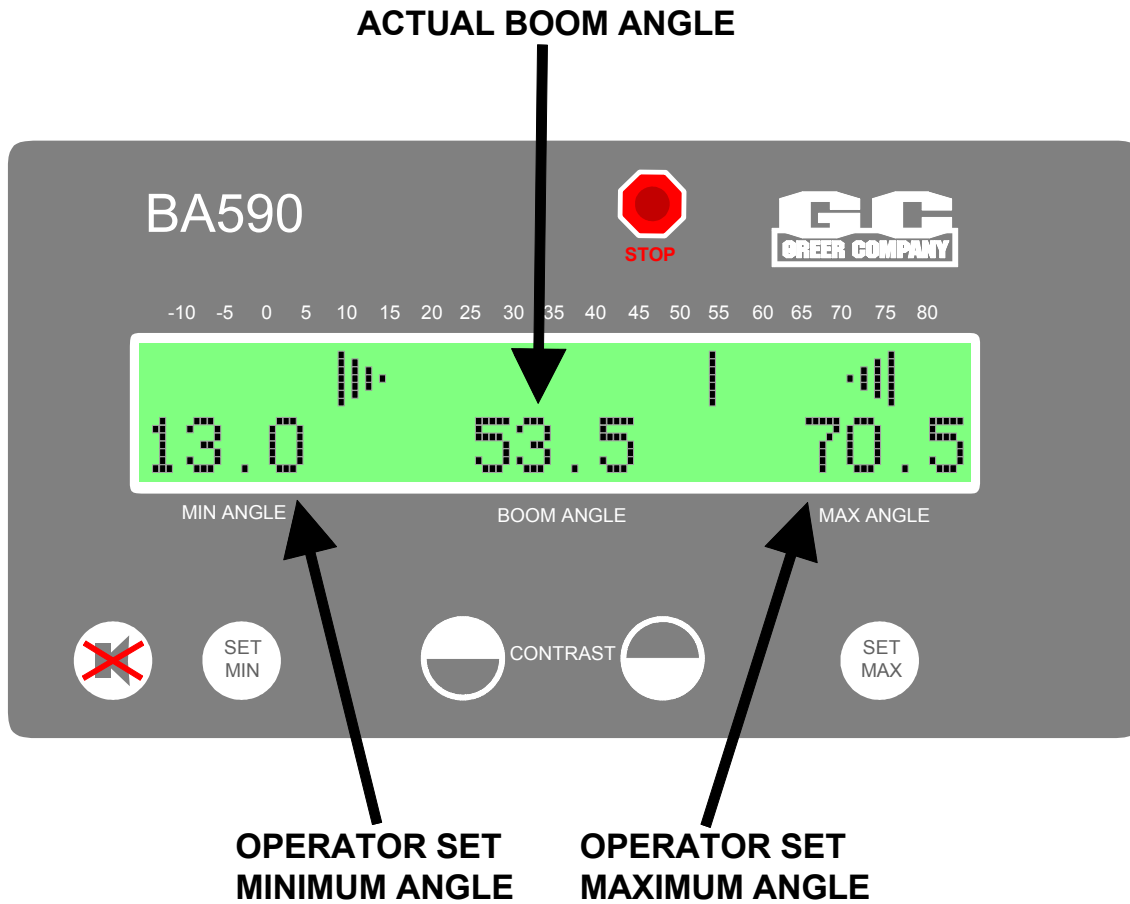

- **Actual boom angle** shows the current working boom angle of the crane. This value will update in real time as the cranes boom is raised and lowered.
- **Operator-set minimum angle** shows the minimum angle alarm trip value that the operator has set. If no limit has been set, the word "OFF" will be displayed instead of any numeric value.
- **Operator-set maximum angle** shows the maximum angle alarm trip value that the operator has set. If no limit has been set then the word "OFF" will be displayed instead any numeric value.

The top display line will exhibit the information shown on the following page.

3. What's on the display? continued

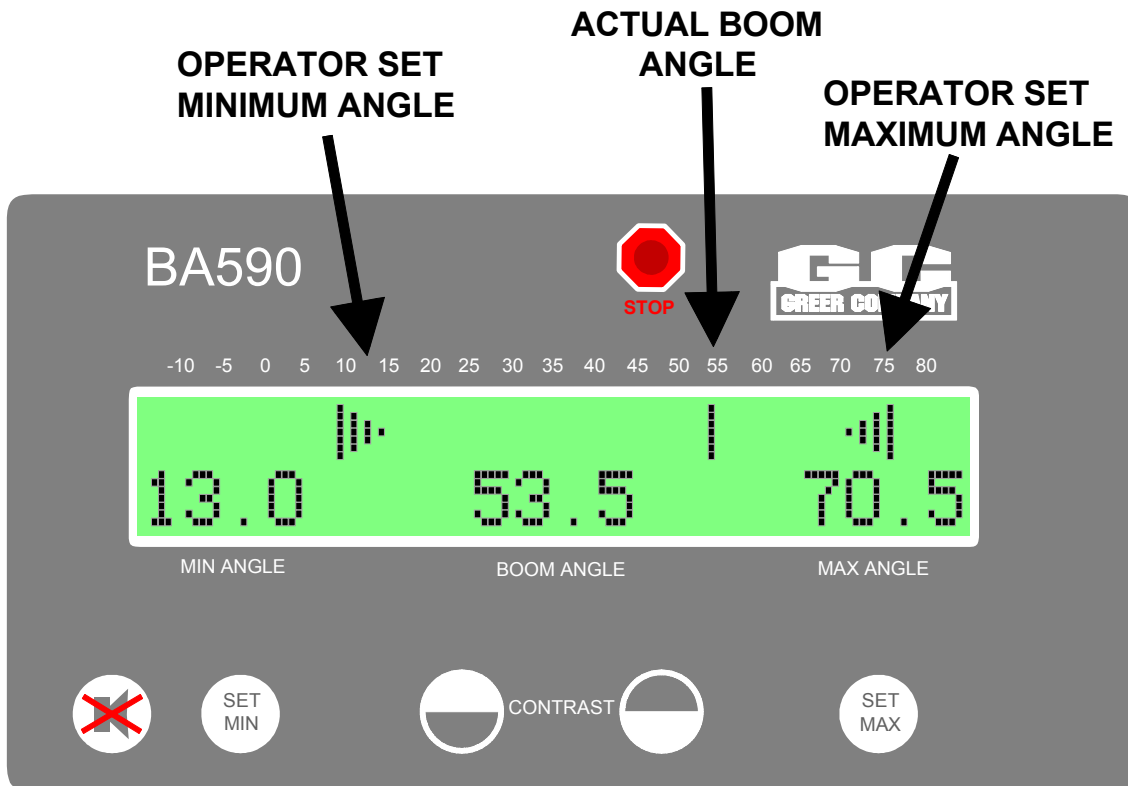

- **Actual boom angle** is a representation of the current working boom angle expressed as a bar graph. The bar can be lined up with the white numerals across the top of the display to give a quick approximate angle reading.
- **Operator-set minimum angle** is a representation of the minimum alarm trip value that the operator has set. The tip of the arrow can be lined up with the white numerals across the top of the display to give a quick and approximate limit set reading.
- **Operator-set maximum angle** is a representation of the maximum alarm trip value that the operator has set. The tip of the arrow can be lined up with the white numerals across the top of the display to give a quick and approximate limit set reading.

4. Adjusting the display contrast.

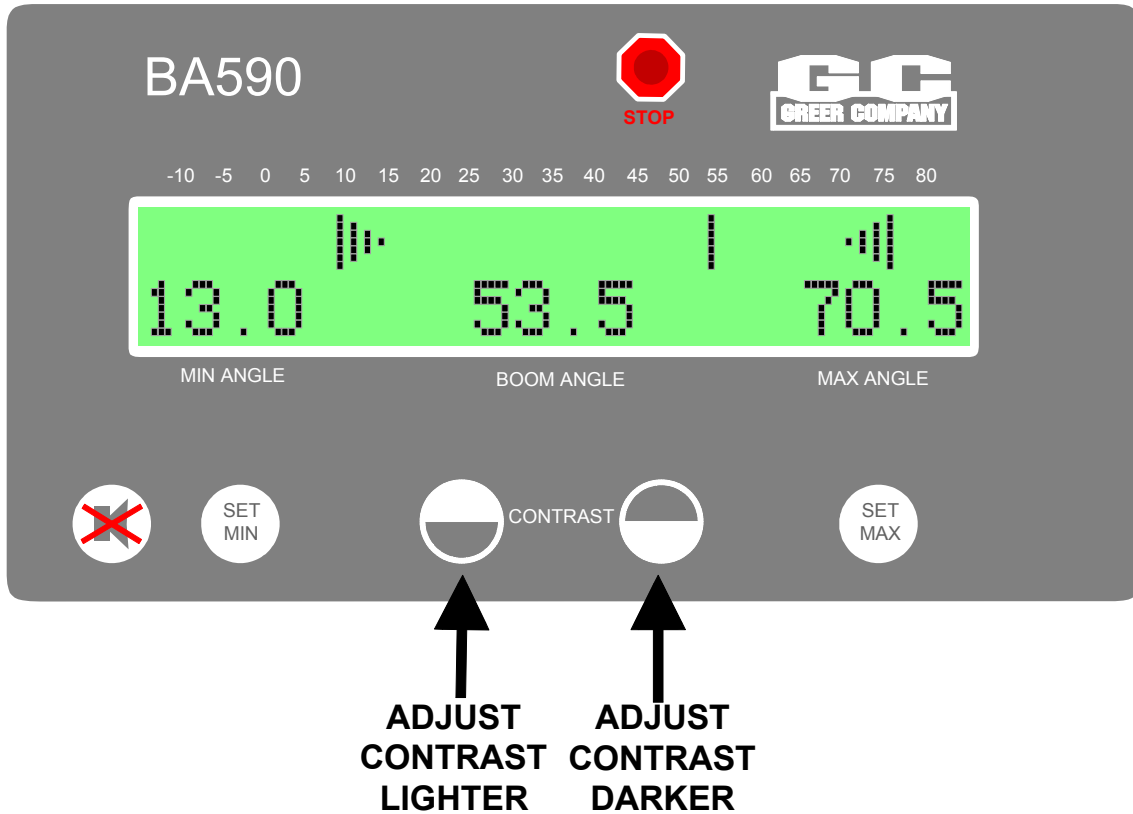

The angle indicators display contrast is self-adjusting to cater for different temperature conditions; however, it may be necessary to adjust the contrast for different or unusual lighting conditions.

Simply use the two contrast control buttons to raise and lower the contrast for the display unit.

5. Setting, removing, and adjusting angle alarm limits.

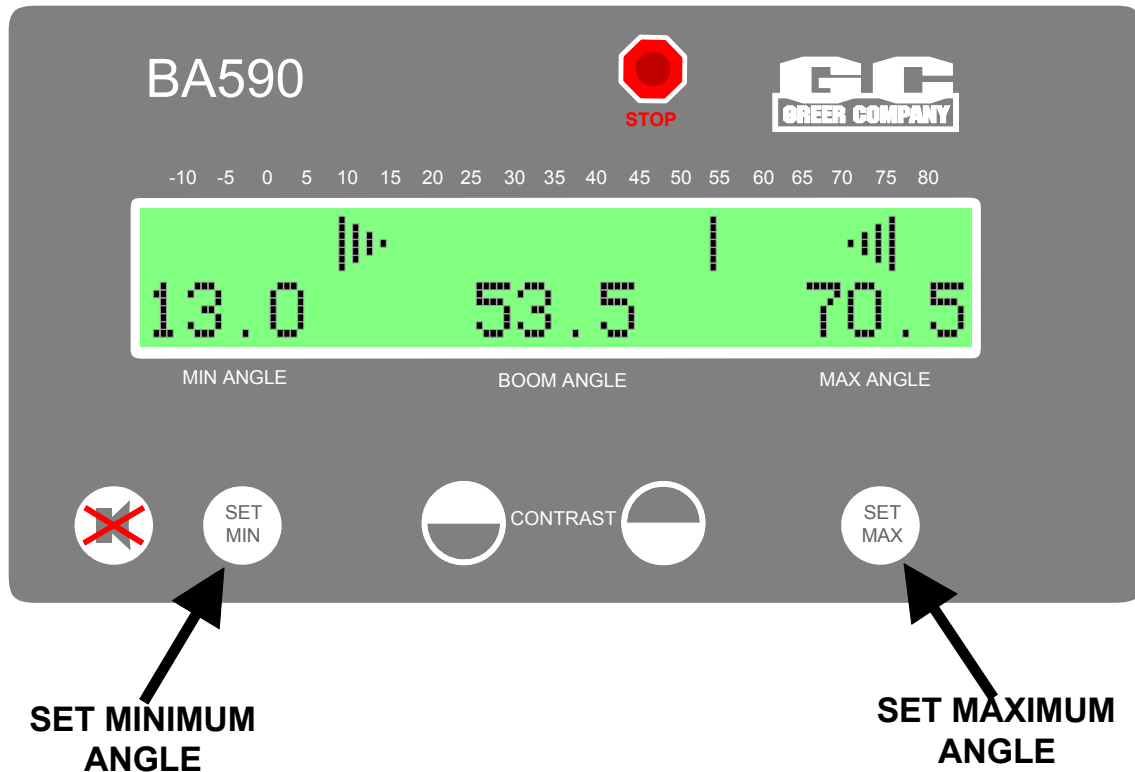

To set a minimum angle alarm trip:

1. Position the crane boom at or just above the desired limit.
2. Press the “Set minimum angle” button.
3. The set limit should appear in the display area marked “MIN ANGLE.”
4. If it is desired to move the limit down, continue to hold down the “Set minimum angle” button and the limit arrow will move down slowly in steps of one half of a degree.
5. When the desired limit is reached, remove finger from the button.
6. The minimum limit for the display is -15° , however the system will operate below this value. If a limit is set below the -15° limit then no arrow will be displayed, but the limit will be active.

To set a maximum angle alarm trip:

1. Position the crane boom at or just below the desired limit.
2. Press the “Set maximum angle” button.
3. The set limit should appear in the display area marked “MAX ANGLE.”

-
4. If it is desired to move the limit up, continue to hold down the “Set maximum angle” button and the limit arrow will move up slowly in steps of one half of a degree.
 5. When the desired limit is reached, remove finger from the button.
 6. The maximum limit for the display is **85°**, however, the system will operate above this value. If a limit is set above the **85°** limit, no arrow will be displayed but the limit will be active.

To remove a minimum angle alarm trip:

1. Press the “Set minimum angle” button.
2. The low angle trip arrow will be removed and the trip angle on the display “MIN ANGLE” box will be replaced by an “OFF” message.
3. No angle alarm will sound no matter how low the boom angle goes now!

To remove a maximum angle alarm trip:

1. Press the “Set maximum angle” button.
2. The high angle trip arrow will be removed and the trip angle on the display “MAX ANGLE” box will be replaced by an “OFF” message.
3. No angle alarm will sound no matter how high the boom angle goes!

6. Alarms and canceling the audible alarm.

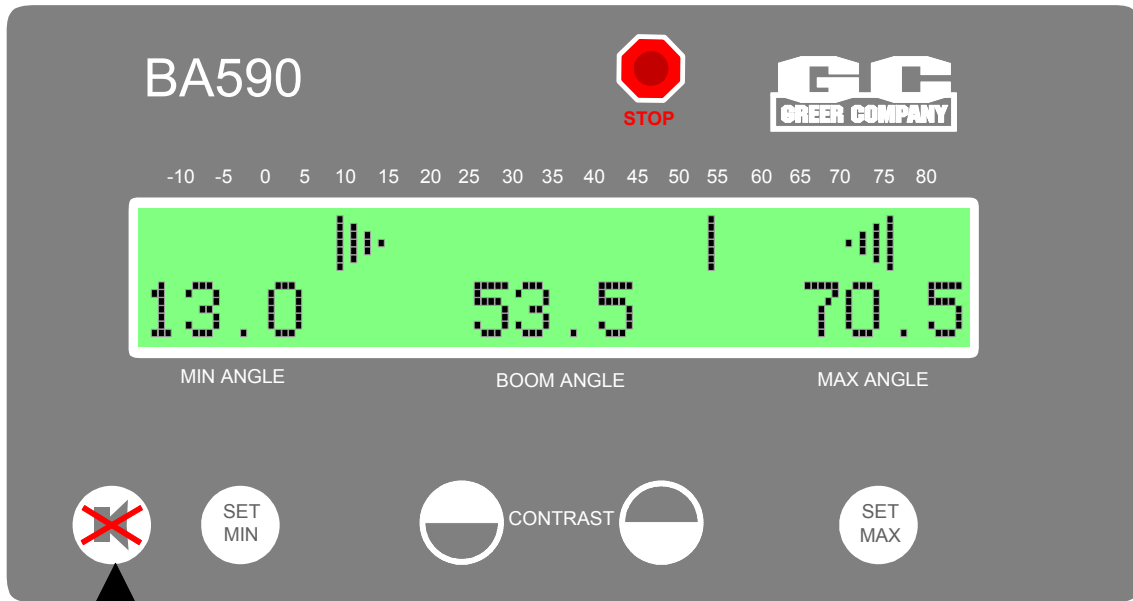

**CANCEL
ALARM**

An alarm condition occurs when the current working boom angle either goes lower than the low angle alarm trip point or goes above the high angle alarm trip point.

When this condition occurs the audible warning sounds, the red warning lamp illuminates, and the alarm limit that has been crossed will flash.

When the audible alarm sounds, it can be cancelled by pressing the "Cancel Audible Alarm" button.

The audible alarm will then not sound until another alarm condition is created.

7. BA591 system installation.

The BA591 Angle indicator connects to an existing Greer MicroGuard® LMI installation and uses boom angle information from the already installed LMI angle sensor.

LMI system program chip

For the angle indicator to work properly in this configuration, a compatible program chip must have been installed within the LMI system computer. Check with the factory to determine if an upgrade chip is required, before using the angle indicator.

Indicator connection

The BA-590 unit connects between the existing LMI display console and the LMI system computer. The existing LMI cable connection must be disconnected at the rear of the LMI display console and reconnected to the connector at the rear of BA-590 display console.

A short, pre-installed connection lead exits the rear of the BA-590 console and connects to the LMI console.

NOTE: If the LMI system angle sensor has been correctly setup during the LMI installation, there are no calibration steps required before using the angle indicator.

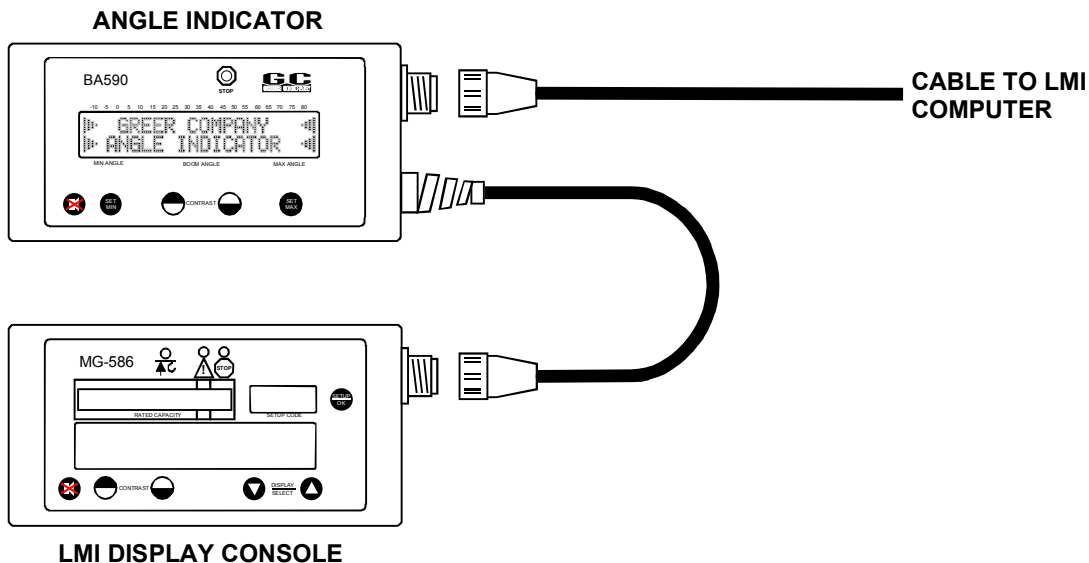

8. BA590 System installation.

The *BA590 Angle indicator system* requires connection to a boom angle sensor as a complete independent system for operation.

System power cable connection

A pre-installed power cable exits the rear of the Indicator unit. A battery positive and battery negative connection must be made to this cable.

The BA-590 is internally protected by an automatically resetting circuit breaker. The internal protection **does not provide protection for the power cable itself**. The power cable must be connected to an existing circuit breaker or an in-line fuse (5 Amp).

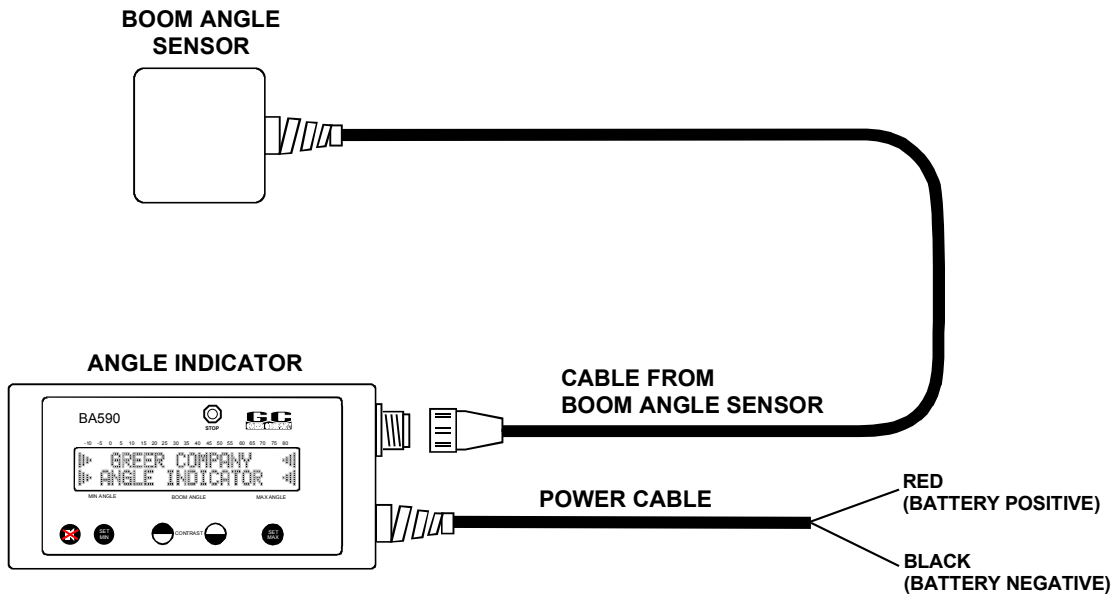

Angle sensor mounting

The angle sensor must be carefully mounted on the left-hand side of the boom with its cable exiting from the underside of the unit. Any position on the base section is acceptable, as long as the cable will reach the display unit sensibly. Consider the routing of the cable to ensure that it is not pinched or pulled by the boom at any point in its range of motion.

The sensor is supplied with an integral mounting bracket. This bracket allows the use of 1/4" hardware (not supplied) to anchor the unit securely to the boom structure. A 1:1 scale 'tear-out & tape on' template showing the required mounting centers can be found on the next page.

To install the sensor, lower the boom to horizontal (using a quality 'bubble' level or similar to establish this), add the fixings (using the supplied template) at the selected site and apply the device. The right-hand slot in the bracket allows the unit to be 'trimmed' level (put the 'bubble' level on top of the unit to do this). Then, secure the cable run back to the display unit, taking time to verify that there will be no interference between the machine structure and the cable at any time.

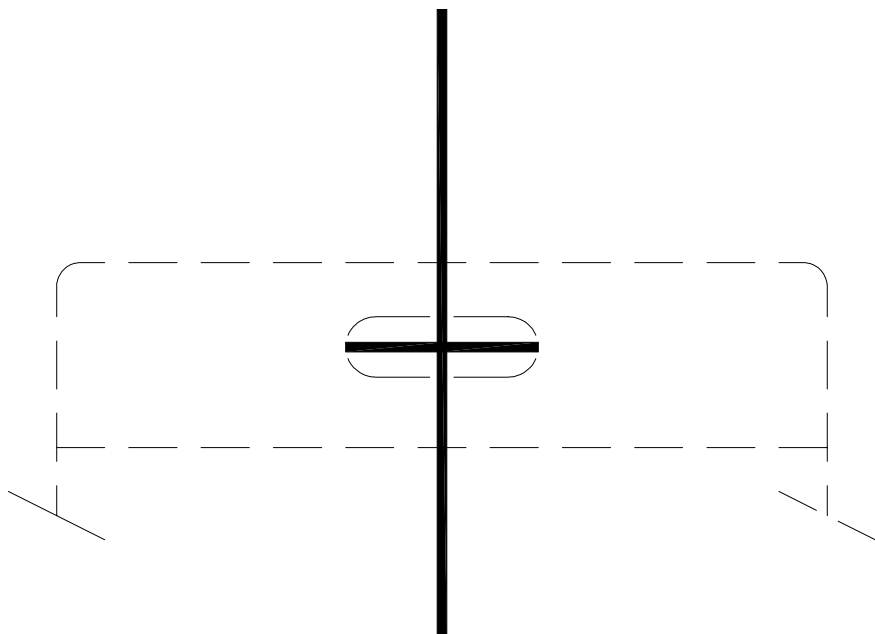

THIS LINE LEVEL WITH
BOOM HORIZONTAL

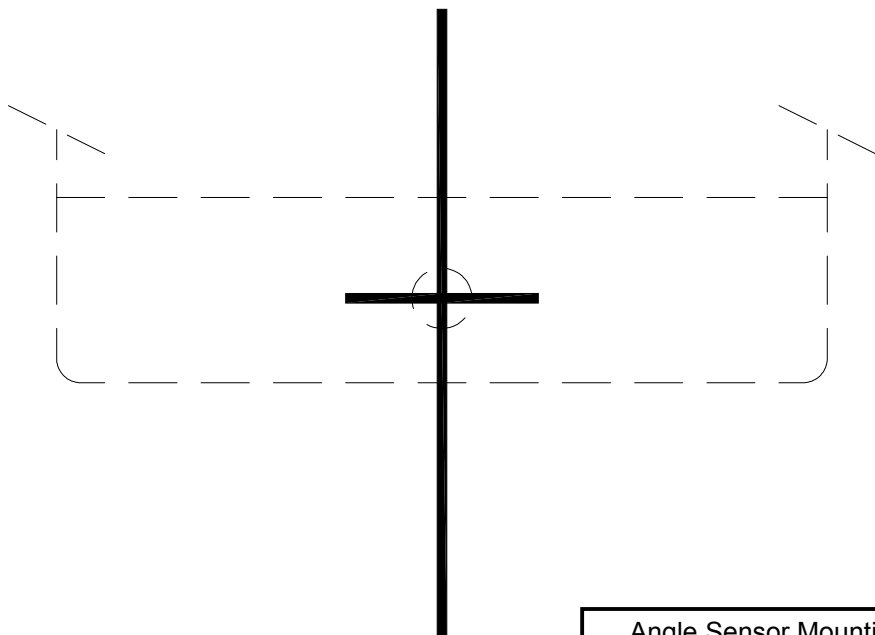

Angle Sensor Mounting Template

Angle sensor cable connection

A pre-wired fixed length cable exits the angle sensor on its right-hand side and terminates in a connector that must be connected to the connector at the rear of the indicator unit. Run the cable down the boom base and into the crane turret, ensuring that enough cable slack and protection is allowed to prevent damage during movements of the boom.

Route the cable to the Indicator unit and connect to the connector at the rear of the unit. Slack, unused cable length may be coiled up and secured in a protected position (preferably within the crane turret).

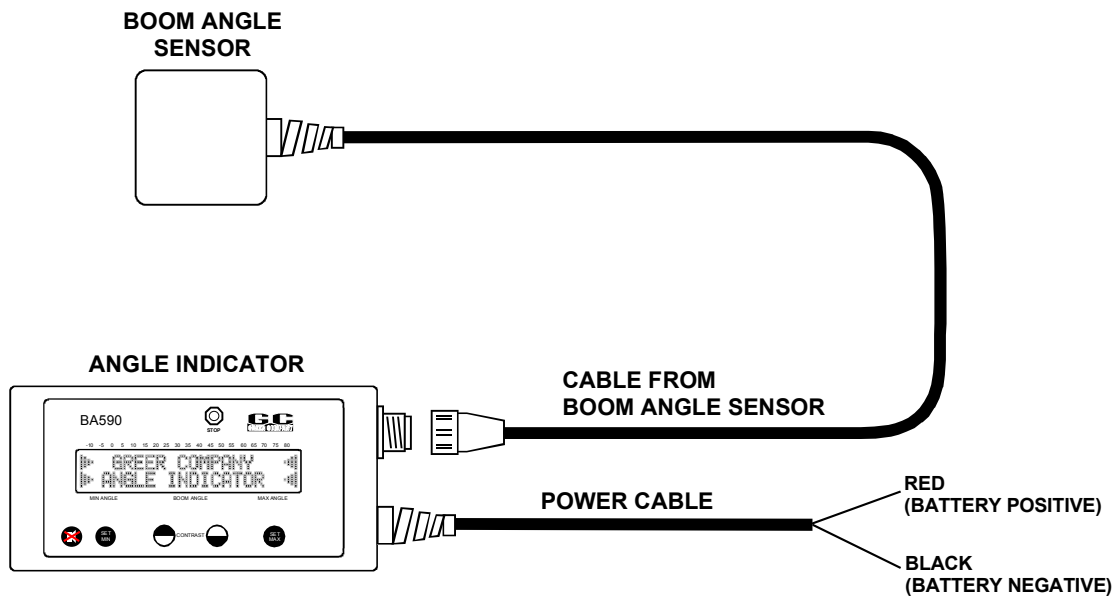

9. Inspection & maintenance.

BA591 System

Before each work shift ...

1. Check that interconnecting cables to and from the *Angle indicator* unit are free from damage and that all connectors are properly tightened.
2. Check that maximum and minimum alarms can be set and both visual and audible alarms operate.
3. Follow routine maintenance schedules detailed within the Operator's Manual for the LMI system.

Annually ...

1. Using an accurate inclinometer, measure the boom angle and compare with the angle displayed on the console. Check the angle value at two points (one low angle and one high angle). The displayed angle value should match the inclinometer reading within +/-1 degree.

BA590 System

Before each work shift

1. Check that interconnecting cables to and from the *Angle indicator* unit and the angle sensor are free from damage and that all connectors are properly tightened.
2. Check that the angle sensor is securely attached to the side of the boom base, and has not been disturbed. If the angle sensor is ever removed, it is necessary to complete the setup procedure contained in this manual.
3. Check that maximum and minimum alarms can be set and both visual and audible alarms operate.

Annually ...

1. Using an accurate inclinometer, measure the boom angle and compare with the angle displayed on the console. Check the angle value at two points (one low angle and one high angle). The displayed angle value should match the inclinometer reading within +/-1 degree.

10. Troubleshooting & Servicing

If the Installation, Setup and Maintenance procedures detailed within this manual have been correctly followed, the BA590/591 Angle Indicator should give trouble-free operation. Should a problem occur, perform maintenance checks detailed in this manual before taking further action.

NOTE:

Servicing of this product is limited to replacement of system units and associated cabling. There are **no user-serviceable parts** contained within the Angle indicator unit or the angle sensor. Any access gained to internal parts of these units may cause damage that affects the operation of the product, and will invalidate warranty.

