

MicroGuard[®] 424

INSTALLATION DATA

*For
 Upgrades from MG- 3 & RLI-200
 and
 Retrofits to unfitted machines*

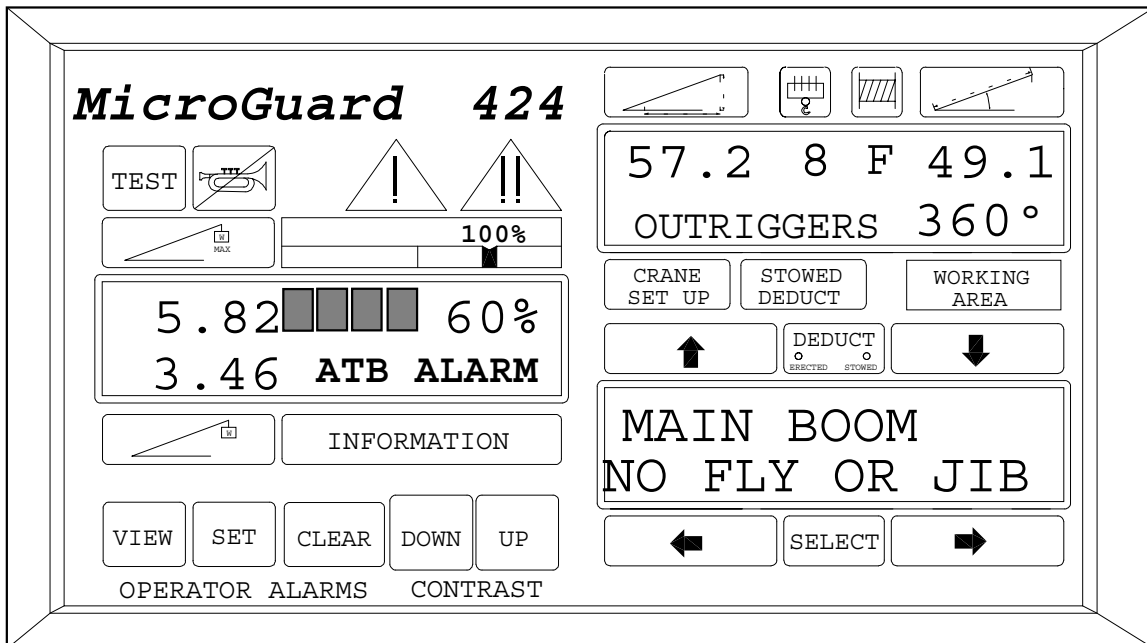

WARNING

This MicroGuard® 424 System Manual is designed to assist the fully trained and experienced crane technician in the safe and proper installation of the MicroGuard® 424 System. At no time may this System be used as a substitute for the usual safety practices and precautions required for the safe setup and operation of the crane.

TABLE OF CONTENTS

MicroGuard® 424 System

SYSTEM COMPONENTS	5
SYSTEM REMOVAL AND INSTALLATION	6
UPGRADING OLDER GREER SYSTEMS	6
EXTENSION REEL	6
ANTI TWO-BLOCK CIRCUIT	6
DISPLAY	7
COMPUTER	7
PRESSURE TRANSDUCERS	7
EXTENSION REEL CABLE TO COMPUTER	7
ANGLE SENSOR	8
BULKHEAD CONNECTOR	8
A047013 CABLE	8
PROCEDURE FOR CONNECTING CABLE SHIELDS	9
SYSTEM COMPUTER	10
CABLE SCHEDULE	11
CABLE 1 PISTON PRESSURE TRANSDUCER	11
CABLE 2 ROD PRESSURE TRANSDUCER	11
CABLE 3 BOOM EXTENSION, BOOM ANGLE AND ANTI TWO-BLOCK SIGNAL	11
LINK-BELT WIRING ON MG-3 SYSTEMS	12
CABLE 6 SWING SWITCH INPUTS	13
CABLE 7 DISPLAY	13
CABLE 8 POWER AND FUNCTION KICKOUT	14
SYSTEM BYPASS SWITCH	14
ATB BOARD CONNECTIONS	14
MEASUREMENTS CRITICAL TO CALIBRATION	15
MICROGUARD® 424 APPLICATION DATA SHEET TELESCOPIC CRANES	16
SWING DATA	17
BOOM HOIST DATA	18
WINCH DATA	19
DEAD END BECKET DATA	20
MAIN BOOM DATA	20
ATTACHMENT DATA	21-25

APPENDICES 26-30

APPENDIX A EXTENSION REEL LAYOUT26

APPENDIX B BULK HEAD CONNECTOR SCHEMATIC27

APPENDIX C REEL TO COMPUTER CABLE ASSEMBLY28

APPENDIX D BULK HEAD CONNECTOR.....29

APPENDIX E DISPLAY TO COMPUTER CABLE ASSEMBLY30

APPENDIX F EXTENSION REEL MOUNTING (HYDRAULIC)31

APPENDIX G BOOM HEAD ANTI TWO-BLOCK SWITCH32

RETROFIT CALIBRATION REPORT 33-34

Warning

Improper installation of program and duty chips will damage them. The correct way to install these chips is to align the notch on the socket and the notch on the chip at the same end. This must be done with the power to the system "OFF."

GREER COMPANY

Crane Systems

SYSTEM COMPONENTS

ITEM	DESCRIPTION	PART NUMBER	QUANTITY
1	DISPLAY, HORIZONTAL	A444111	1
2	COMPUTER, GLANDED	A440103	1
3	EXTENSION REEL, INCL. EXTENSION AND BOOM ANGLE SENSORS	A240160	1
4	PRESSURE TRANSDUCERS	A200000	2
5	MAIN A2B SWITCH	A250006	1
6	JIB/AUX HEAD A2B SWITCH	A250019	AS REQ.
7	CHAIN AND WEIGHT	A251000	AS REQ.
8	SWING SWITCH AND ARM	K035012	1
9	HYDRAULIC CUT OUT VALVES, 40 GPM	P070000 (12 VOLT)	AS REQ.
10	HYDRAULIC CUT OUT VALVES, 40 GPM	P070000 (24 VOLT)	AS REQ.
11	HYDRAULIC CUT OUT VALVES, 70 GPM	P070001 (12 VOLT)	AS REQ.
12	HYDRAULIC CUT OUT VALVES, 70 GPM	P070001 (24 VOLT)	AS REQ.
13	EYEBOLT KIT FOR EXTENSION REEL CABLE	K056003	1
14	CABLE, EXTENSION REEL	AO47013	1
15	CABLE, DISPLAY	AO47062	1
16	CABLE, 20 AWG, SWING CABLE	P045051	20FT
17	CABLE, 16 AWG, POWER AND FKO	P045052	20FT
18	CABLE, JIB A2B, LENGTH AS REQUIRED	A048000+LENGTH	AS REQ.

FOR RETROFIT SYSTEMS WHICH DO NOT REQUIRE A NEW EXTENSION REEL, A NEW BOOM ANGLE SENSOR AND CABLE WILL BE NECESSARY. DELETE ITEM 3 FROM THE PRECEDING LIST AND ADD ITEMS 19 & 27 FROM THE FOLLOWING LIST.

19	BOOM ANGLE SENSOR	A220220	1
20	BULKHEAD CONNECTOR	S047250	1
21	RING TERMINALS	P050753	6
22	P- CLAMP	P040376	1
23	CABLE CLAMP	P050311	2
24	#4-40 X 1/2" SCREW	P050084	1
25	1/4" X 20 NUT	P050219	2
26	1/4" WASHER	P050214	2
27	IN - LINE FUSE	P037106	1

SYSTEM REMOVAL AND INSTALLATION

UPGRADING OLDER GREER SYSTEMS (LA-1250, LAR-1200, BA-1500, & LOHD-1100)

EXTENSION REEL

1. REMOVE THE COVER ON THE EXISTING EXTENSION REEL.
2. CLAMP THE CABLE FROM THE SENSOR TO THE TRIANGLE PLATE USING CABLE CLAMPS. ENSURE THAT THE CABLE FROM THE ANGLE SENSOR DOES NOT INTERFERE WITH THE EXTENSION REEL CABLE OR WITH THE EXTENSION REEL ITSELF.

ANTI TWO-BLOCK CIRCUIT

For MicroGuard® 424 System installations, the anti Two-Block circuit must be isolated. Two terminal strips require this modification. One strip is located on the triangle plate and the other is on the extension reel.

TO ISOLATE THE CIRCUIT:

1. STARTING WITH THE TRIANGLE PLATE TERMINAL STRIP, MOVE THE TOP BROWN WIRE TO TERMINAL #5 AND THE TOP BLACK WIRE FROM THE MOUNTING SCREWS TO TERMINAL #6.
2. ON THE SPOOL TERMINAL BLOCK, REMOVE THE 2 CENTER SCREWS. REPLACE THEM WITH THE #4-40X $\frac{1}{4}$ " SCREWS AND SECURE THE WIRES TO THE TERMINAL ACCORDING TO APPENDIX A.

NOTE: USE A CABLE CLAMP AND ONE OF THE EXISTING SCREWS ON THE EXTENSION REEL COVER TO HOLD THE EXCESS CABLE. THIS WILL PREVENT THE CABLE FROM GETTING CAUGHT ON THE REEL.

DISPLAY

Mount the display in the cab where it can be easily observed without obstructing the view through the cab window. Position the display cable so that it will not hinder the normal operation of the levers and controls of the crane.

COMPUTER

Mount the computer inside or outside of the cab with the cable glands facing down. Ensure that there is enough cable line from the other sensors. **Note:** The cable to the pressure transducers **cannot be increased** by splicing in additional cable.

PRESSURE TRANSDUCERS

Do not remove the existing transducers in the hydraulic system unless a failure occurs. If the transducers are confirmed to have failed, then replace them accordingly. On upgrades from the RLI-200, it will be necessary to remove the connectors from the computer end of the cable. Do this, but cut the cable as close to the connector as possible. This will give you as much cable length as possible.

EXTENSION REEL CABLE TO COMPUTER

Connect the cable to the extension reel. Route the cable to avoid cable damage, i.e., cutting or pinching during the normal movement of the boom.

When upgrading the existing extension reel with a new angle sensor and connector, use the following table for wiring at the extension reel terminal block. Use Appendices A-D for reference. Use Cable A047013 from extension reel to computer.

ANGLE SENSOR

See Appendix A for installing the Angle Sensor to existing extension reel. Route the cable to the terminal block, clamping the cable along the top of the triangle plate. Use ¼ -20 nuts to mount the angle sensor to the existing studs in the extension reel.

BULKHEAD CONNECTOR

Appendix D illustrates the supplied bulkhead connector to replace the existing connector. It also has terminal connections. Use in conjunction with the table shown above. Appendix B shows how the Extension and Angle sensor as well as the Anti Two Block signal is connected to the terminal block with the bulkhead connector.

A047013 CABLE

Appendix C is for cable A047013. This cable connects the extension reel to the computer. Use Appendix C in conjunction with the Cable 3 wiring table on page 11.

INSTALLATION OF NEW ANGLE SENSOR AND NEW STYLE CONNECTOR TO UPDATE REEL

BLR-800C / 801C TO BLR-805D

Pin Designation	Reel Terminal Block	Wire Color	Computer Connection
N	1	RED	+DR
E	2	BLUE	-DR
D	3	WHITE	AIN 2
A	4	GREEN	AIN 3
G	5	BROWN	ATBIN
B	6	BLACK	0V

PROCEDURE FOR CONNECTING CABLE SHIELDS

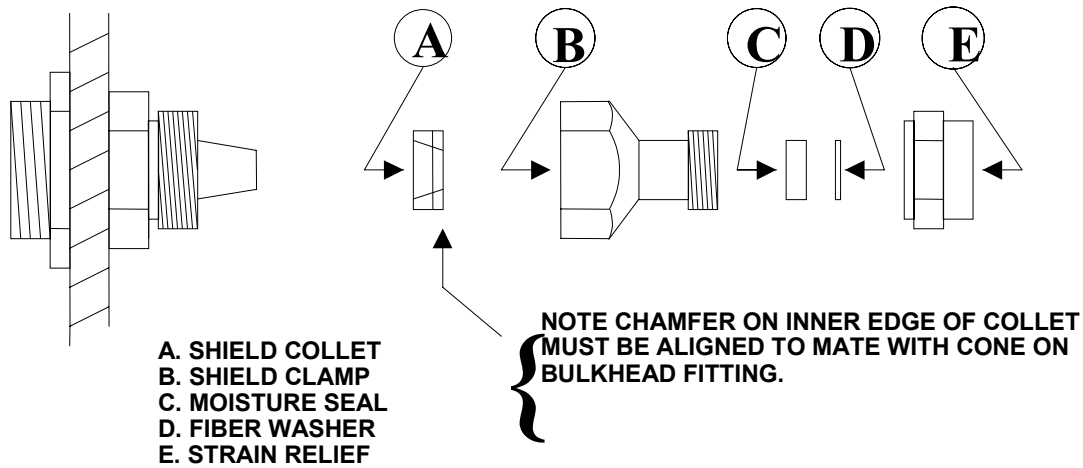

1. PASS SECTIONS A. THROUGH E. OVER THE CABLE IN THE ORDER SHOWN.

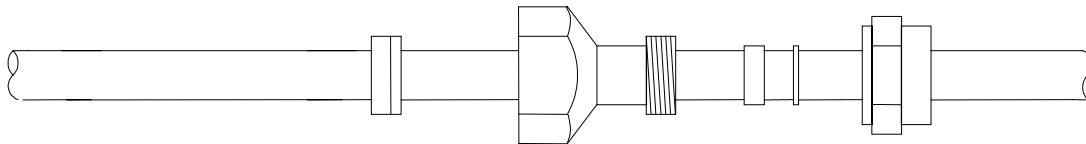

2. STRIP BACK THE OUTER COVER OF THE CABLE EXPOSING THE SHIELD.

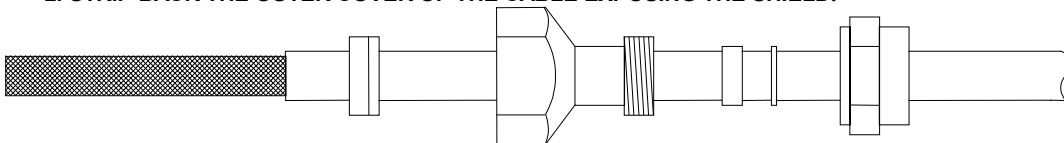

3. TRIM BACK THE BRAID TO APPROX. 0.25" AND DRAW OUT TO A CONE SHAPE TO CONFORM TO THE GLAND CONE. PASS THE CABLE CONDUCTORS THROUGH THE BULKHEAD LOCATING THE SHIELD OVER THE CONE. SLIDE THE COLLET (ITEM A) OVER THE SHIELD AND LOCK IT IN POSITION BY SCREWING DOWN THE CLAMP (ITEM B) UNTIL TIGHT. FINALLY POSITION THE MOISTURE SEAL AND FIBER WASHER (ITEMS C & D) AND TIGHTEN DOWN THE STRAIN RELIEF (ITEM E).

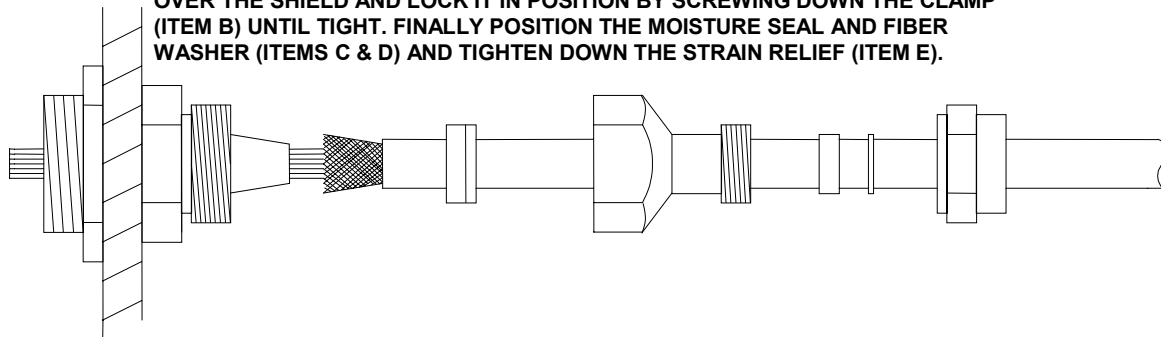

GREER COMPANY
Crane Systems
SYSTEM COMPUTER

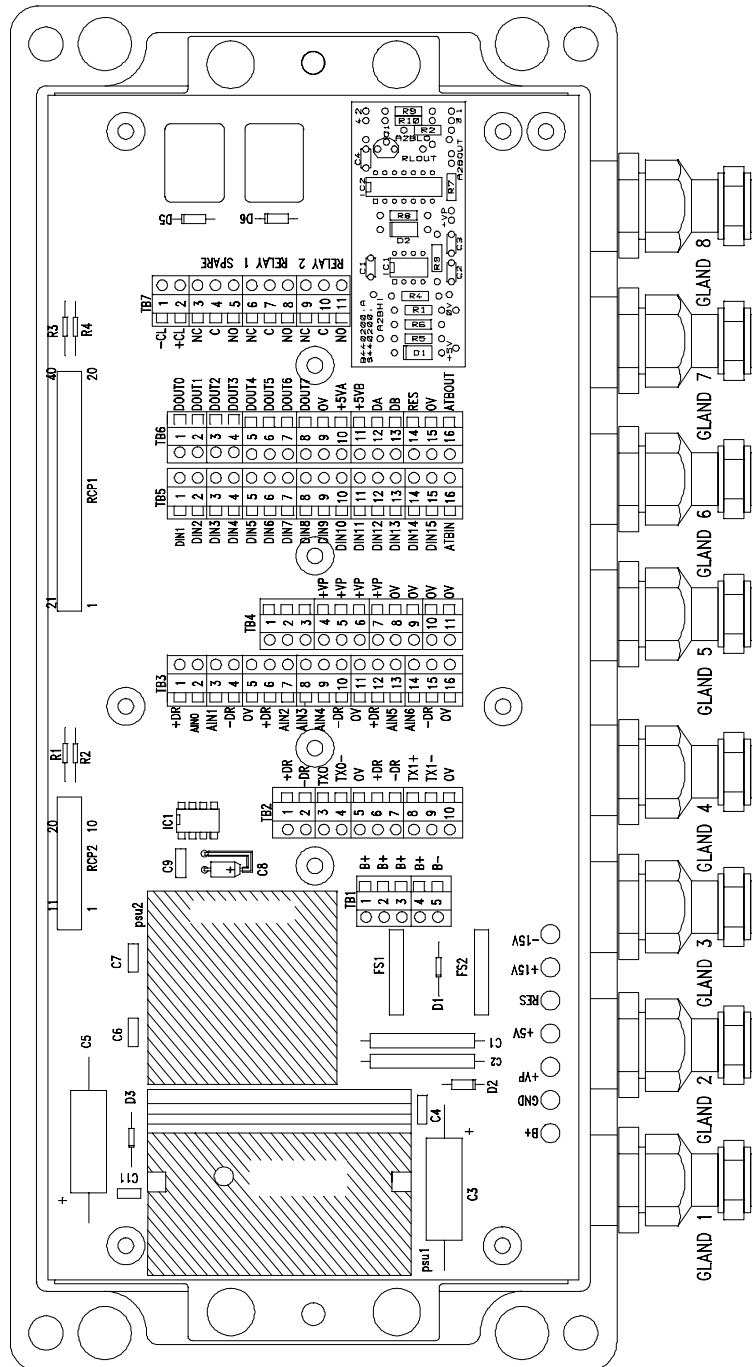

CABLE SCHEDULE

The following section contains information pertaining to the wiring of the sensors. Terminate the shields (if applicable) as described on page 8. Insert the cables through the glands as shown on page 9.

CABLE 1

PISTON PRESSURE TRANSDUCER

4 CONDUCTOR SHIELDED

CABLE COLOR	FUNCTION	COMPUTER	TERMINAL
RED	TRANSDUCER DRIVE +	+DR	TB 2
BLUE	TRANSDUCER DRIVE -	-DR	TB 2
YELLOW	TRANSDUCER SIGNAL +	TX0+	TB 2
GREEN	TRANSDUCER SIGNAL -	TX0-	TB 2

CABLE 2

ROD PRESSURE TRANSDUCER

4 CONDUCTOR SHIELDED

CABLE COLOR	FUNCTION	COMPUTER	TERMINAL
RED	TRANSDUCER DRIVE +	+DR	TB 2
BLUE	TRANSDUCER DRIVE -	-DR	TB 2
YELLOW	TRANSDUCER SIGNAL +	TX1+	TB 2
GREEN	TRANSDUCER SIGNAL -	TX1-	TB 2

CABLE 3

BOOM EXTENSION, BOOM ANGLE AND A.T.B SIGNAL

8 CONDUCTOR SHIELDED (6 USED) SEE APPENDIX C

CABLE COLOR	FUNCTION	COMPUTER/TERMINAL	REEL CON'TR
RED	DRIVE +	+DR / TB - 3	N
BLUE	DRIVE -	-DR / TB - 3	D
WHITE	EXTENSION SIGNAL	AIN: 2 / TB - 3	E
BROWN	A.T.B SIGNAL	A.T.B IN / TB - 5	G
BLACK	A.T.B GROUND	0V / TB - 4	B
GREEN	BOOM ANGLE SIGNAL	AIN: 3 / TB - 3	A
ORANGE	NOT USED		
YELLOW	NOT USED		

GREER COMPANY*Crane Systems***CABLES 4 & 5**

NOT USED

TYPICAL LINK-BELT WIRING ON MG-3 SYSTEMS.

USE THE FOLLOWING NUMBERS AND COLORS WHEN CONNECTING WIRES IN THE MG-424 COMPUTER

LINK-BELT WIRE NUMBER AND COLOR	FUNCTION	MG-424 CONNECTION POINT
ORANGE 348 A	SYSTEM POWER INPUT	T/B 1 –B (+)
ORANGE 348 C	SWING SWITCH POWER	T/B 1 – EXTRA B (+)
ORANGE 349 A	FUNCTION K/O POWER SOURCE	T/B 7 RELAY 1 COMMON
BLACK 348 B	SYSTEM GROUND	T/B 1 – B (-)
BLACK 349 G	GROUND FOR K/O VALVES	CONNECT TO GROUND ON CRANE
YELLOW 348 D	AREA DEFINITION SWING SWITCH	DIGITAL INPUT (SEE CABLE 6)
YELLOW 348 E	AREA DEFINITION SWING SWITCH	DIGITAL INPUT (SEE CABLE 6)
YELLOW 349 B	FUNCTION K/O FEED	T/B 7 RELAY 2 N/O

GREER COMPANY

Crane Systems

CABLE 6

SWING SWITCH INPUTS - RT MODELS			SWING SWITCH INPUTS - TRUCK MODELS		
FUNCTION	COMPUTER CONNECTION	WIRE COLOR	FUNCTION	COMPUTER CONNECTION	WIRE COLOR
SWITCH PWR	+B	TBD	SWITCH PWR	+B	TBD
360 CHART	D IN 2	TBD	360 CHART	D IN 2	TBD
OVER FRONT	D IN 3	TBD	OVER REAR	D IN 1	TBD
IN LINE	D IN 7	JUMPER W/ DIN 3	IN LINE	D IN 8	JUMPER W/ DIN 1

Wire colors are determined when they are removed from the old system. We recommend marking each wire with its location before removing it from the discarded computer. Mg-3 systems have the following designations for swing.

DIGITAL INPUT	DESIGNATION
D IN 4	OVER REAR
D IN 5	IN LINE
D IN 6	360
D IN 7	OVER FRONT

Note: RLI 200 Systems do not need swing inputs. Install jumper between +VP and DIN2.

CABLE 7

DISPLAY

8 CONDUCTOR SHIELDED - SEE APPENDIX E

CABLE COLOR	FUNCTION	DISPLAY CON'TR	COMPUTER/ TERMINAL
WHITE	DATA LINE A	6	DA / TB - 6
BLACK	DIGITAL 0V	2	0V / TB - 6
ORANGE	DIGITAL 0V	4	0V / TB - 6
BLUE	RESET LINE	8	RES. / TB - 6
GREEN	DATA LINE B	7	DB / TB - 6
YELLOW	+5VA	1	+5VA / TB - 6
RED	+5VB	3	+5VB / TB - 6
BROWN	NOT USED		

GREER COMPANY

Crane Systems

CABLE 8

POWER AND FUNCTION KICK-OUT

4 CONDUCTOR 16 AWG SHIELDED

CABLE COLOR	FUNCTION	COMPUTER / TERMINAL
RED	POWER IN	B + / TB - 1
BLACK	GROUND	B - / TB - 1
WHITE	F.K.O +V IN	RL1 COMMON / TB - 7
GREEN	F.K.O +V OUT	RL2 NORMALLY OPEN / TB - 7

Note: This system operates better with two separate power feeds (one for the b+, the other for f.k.o. +v in.)

SYSTEM BY-PASS SWITCH

COLOR	SWITCH	FUNCTION	COMPUTER CON'N / TERMINAL
RED	COMMON	BATTERY +	RL1 COMMON / TB - 7
BLACK	N/O	BY-PASS RELAYS WHEN CLOSED	RL1 NORMALLY OPEN / TB - 7
YELLOW	N/C	SIGNAL BY-PASS WHEN OPEN	DIN: 10 / TB - 5

A.T.B. BOARD CONNECTIONS

COLOR	BOARD LOCATION	COMPUTER CONNECTION / TERMINAL	FUNCTION
RED	1	+ CL / TB - 7	SWG +DR (OUT)
BLACK	3	- CL / TB - 7	SWG -DR (OUT)
VIOLET	A.T.B LO	A.T.B IN / TB - 5	ATB SIGNAL
RED	+ 5V	+ 5VA / TB - 6	BOARD POWER
BLACK	0V	0V / TB - 4	BOARD GND.
WHITE	A.T.B OUT	DIN: 13 / TB - 5	ATB CONDITIONING
RED	2	+DR / TB - 3	SWG +DR (IN)
BLUE	4	-DR / TB - 3	SWG -DR (IN)
YELLOW	+VP	+VP / TB - 4	A.T.B SIG. PULL-UPS
WHITE	RL OUT	DOUT 1 / TB - 6	A.T.B KICK-OUT
ORANGE	A.T.B HI	NO CONNECTION	

MEASUREMENTS CRITICAL TO CALIBRATION

The dimensions illustrated in the following two pages are **vital to the calibration procedure**. These measurements should be obtained during the installation of the components and must be entered into the System **after initializing Personality** and before starting sensor calibration. Follow the instructions for each dimension required. Then, record each dimension on the appropriate page. Double-check the measurements obtained to ensure accuracy.

MICROGUARD® - 424 APPLICATION DATA SHEET - TELESCOPIC CRANES

INFORMATION & OUTLINE OF APPLICATION REQUIREMENTS.

The completion of this application data sheet is required prior to the application of a MicroGuard®-424 rated capacity indicator to any specific machine model. The information provided by this document is used to initialize the calibration of the rated capacity indicator in order to ensure minimum on-site calibration effort. A full capacity chart with detailed notes and range diagrams is required in order to complete the system application.

CRANE OUTLINE

Crane Make & Model

--

Chart Numbers
(Supply with this document)

Units of length
(Check appropriate box)

Feet	Meters
-------------	---------------

Units of force
(Check appropriate box)

Pounds*10 00	Tons(US)	Tons(UK)	Tons(Metric)
-------------------------	-----------------	-----------------	---------------------

SWING DATA

The following dimensions are required when the rated capacity indicator is to be fitted with absolute measurement of swing angle with either a potentiometer or shaft encoder fitted within the center post or to the swing gear.

For machines fitted with swing switch area definition, indicate the appropriate arcs required by the chart.

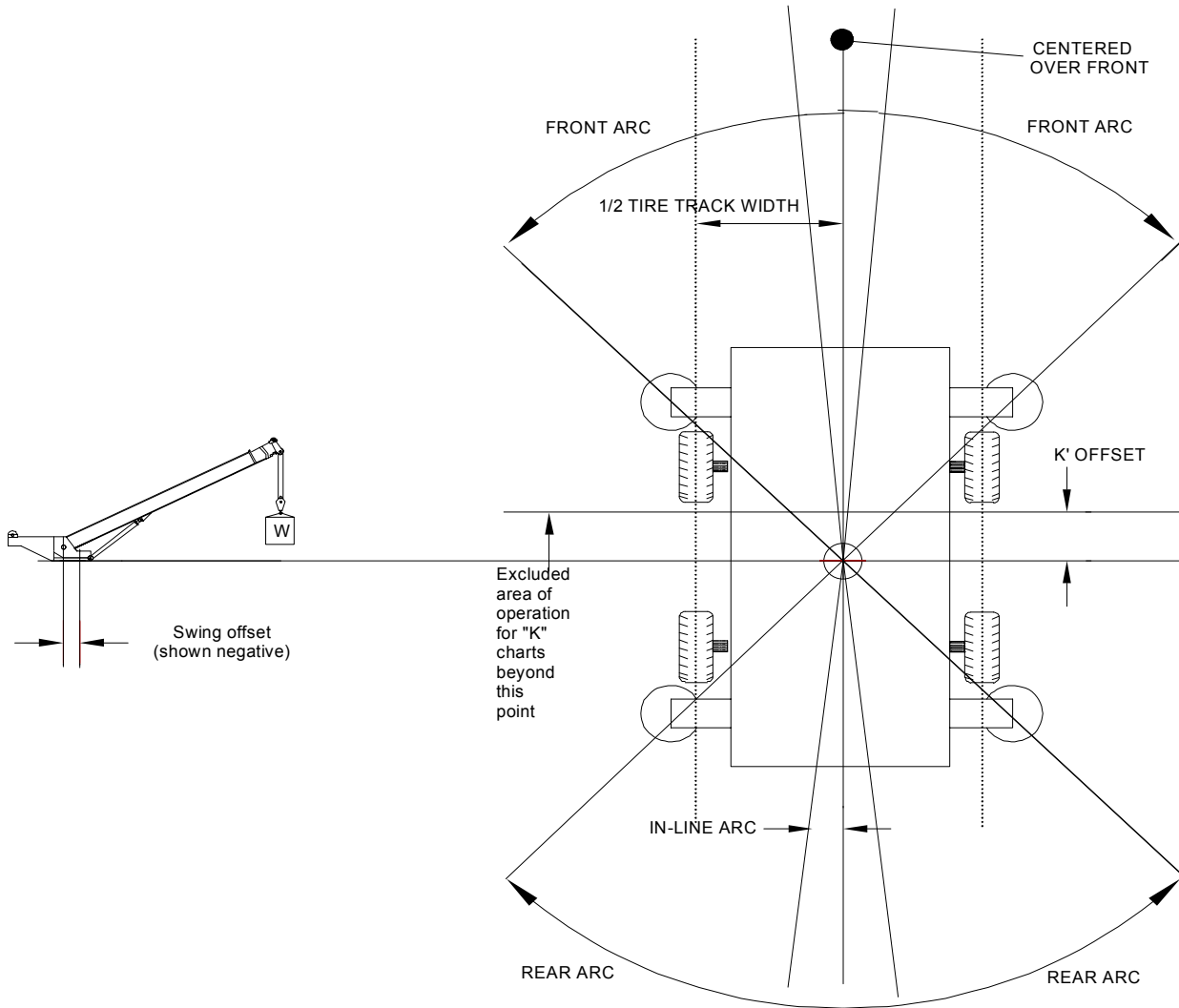

Lengths

Swing Offset

1/2 Tire Track Width

"K" offset

Angles

Front Arc

Rear Arc

In-Line Arc

GREER COMPANY
Crane Systems
BOOM HOIST DATA

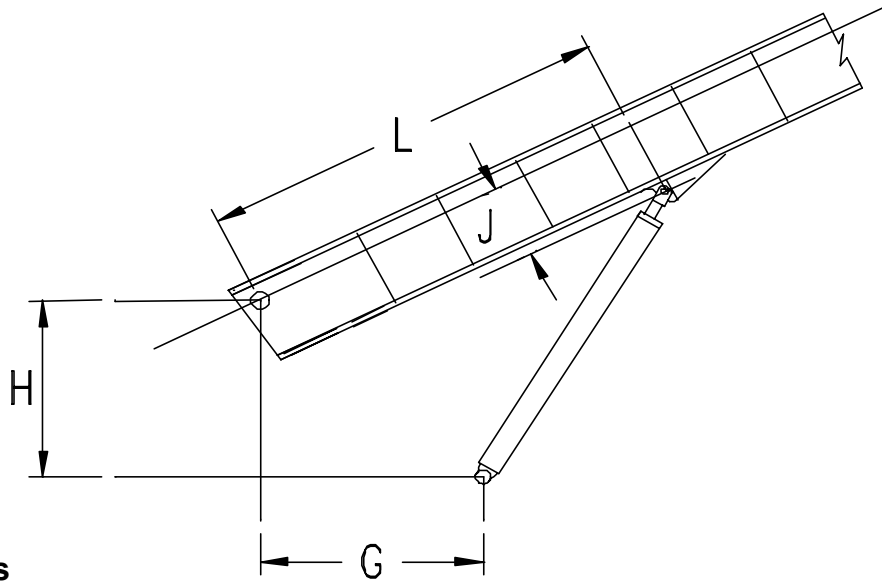

Lengths

L – HORIZONTAL ALONG BOOM FROM BOOM PIVOT TO UPPER CYLINDER PIN	<input type="text"/>
J – VERTICAL ACROSS BOOM FROM BOOM PIVOT TO UPPER CYLINDER PIN NOTE: DIMENSION IS NEGATIVE WHEN BOOM PIVOT IS ABOVE UPPER CYLINDER PIN.	<input type="text"/>
G – HORIZONTAL BETWEEN BOOM PIVOT AND LOWER CYLINDER PIN	<input type="text"/>
H – VERTICAL BETWEEN BOOM PIVOT TO LOWER CYLINDER PIN	<input type="text"/>
B – DIAMETER OF BOOM HOIST CYLINDER BORE	<input type="text"/>
R – DIAMETER OF BOOM HOIST CYLINDER ROD	<input type="text"/>
A.G. – ANNULAR GAIN {A.G. = (R ² ÷B ²) – 1.00}	<input type="text"/>

Note: Result will be a negative value.

WINCH DATA

Winch dimensions are required to allow for compensation of moment arm created by the winch position. For winches mounted on the boom, dimensions are not required.

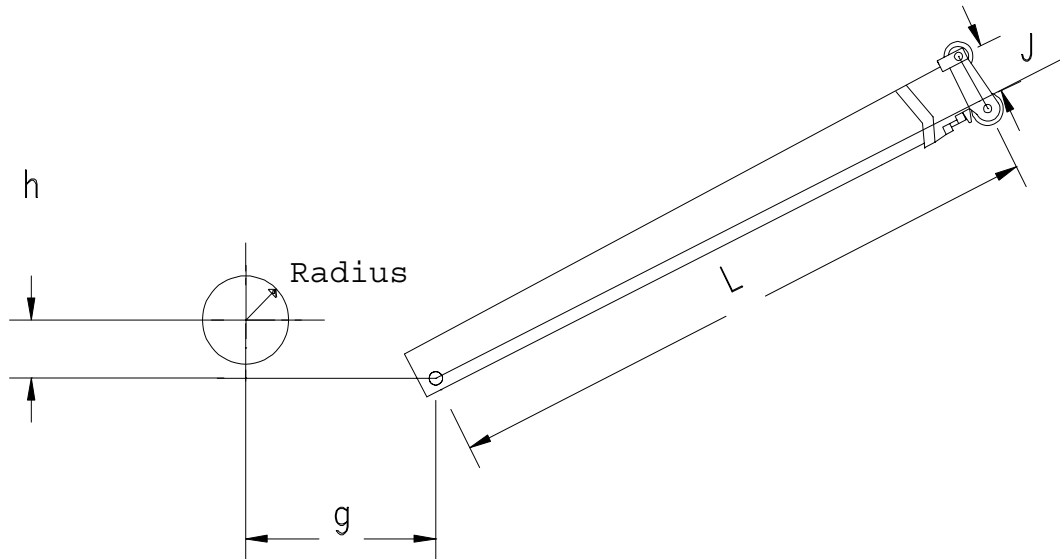

L – HORIZ'L ALONG BOOM FROM BOOM PIVOT TO TOP SHEAVE CENTER (BOOM RETRACTED)

J – VERTICAL FROM BOOM PIVOT TO TOP SHEAVE CENTER (BOOM RETRACTED)

G – HORIZONTAL BETWEEN BOOM PIVOT AND WINCH CENTER OF ROTATION

H – VERTICAL BETWEEN BOOM PIVOT AND WINCH CENTER OF ROTATION

NOTE: THIS DIMENSION IS NEGATIVE WHEN BOOM PIVOT IS ABOVE WINCH CENTER OF ROTATION.

R -- WINCH RADIUS (INCLUDE 2 OR 3 LAYERS OF ROPE)

F – MAXIMUM RATED LINE PULL STANDARD ROPE

MAIN/FRONT
WINCH

AUX/REAR
WINCH

MAIN/FRONT WINCH	AUX/REAR WINCH

DEAD-END BECKET DATA

The below dimensions are used to compute radius offset when using 2-part line on the Auxiliary Head Sheave or any of the Fly's or Jibs.

Dimensions are from the center of main boom or fly/jib sheave to the center of the dead-end becket.

Horizontal offset from dead-end Becket to center-line of the head sheave

MAIN HEAD	FLY/JIB #1	FLY/JIB #2	FLY/JIB #3

Vertical offset from dead-end Becket to center-line of the head sheave

--	--	--	--

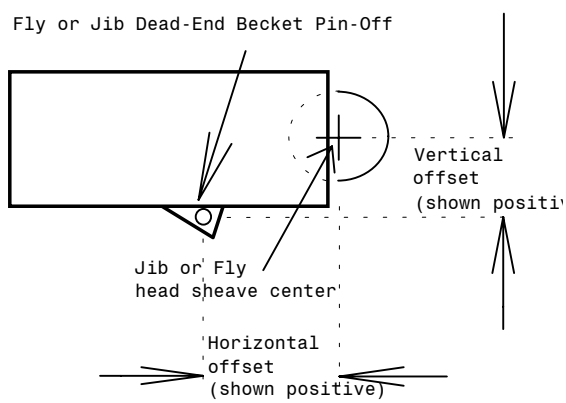
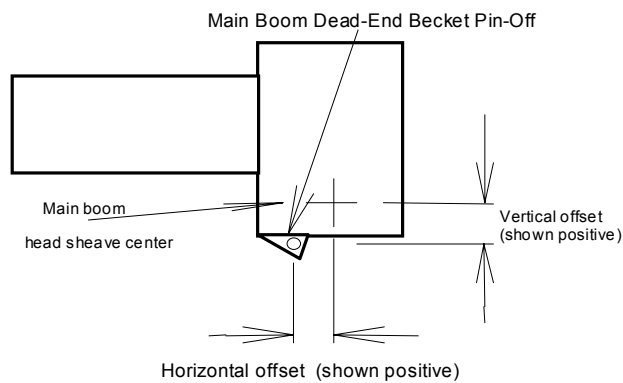

MAIN BOOM DATA

MicroGuard-414 allows for up to four main boom calibrations.

Any configuration of the telescoping boom, which is not detachable and will alter the operating length and/or moment, will require a separate calibration. This will include: Booms with more than one telescoping sequence or boom + manual or powered telescoping tip extension.

Detachable attachments such as lattice fly's, telescoping fly's and auxiliary heads do not require calibration and are covered later in this document.

Main boom head sheave radius

Maximum number of parts of line for main boom

Height of boom pivot above ground (on outriggers)

ATTACHMENT DATA

Attachments are extensions to the boom that are removable. Auxiliary heads should be included as an attachment.

The following attachment data should be specified as accurately as possible to avoid calibration errors. Use data sheet on page 12 to indicate dimensions copy extra sheets as required.

ATTACHMENT LENGTH & HEAD OFFSET

The following dimensions should be specified to the nearest inch.

Attachment length: distance along fly centerline, between fly attachment lower mounting pin and attachment head sheave center.

Attachment head offset: Distance between attachment head sheave center and centerline, perpendicular to centerline.

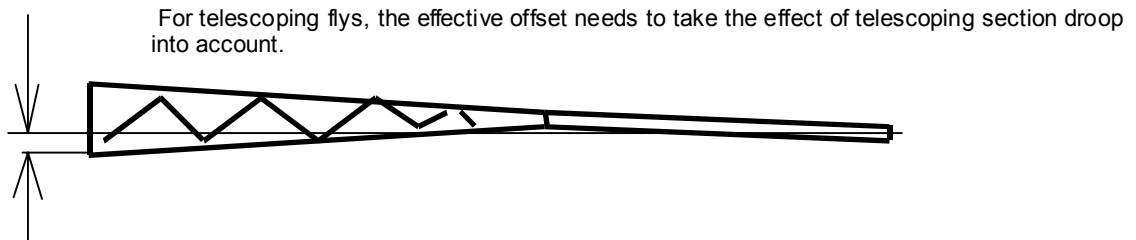
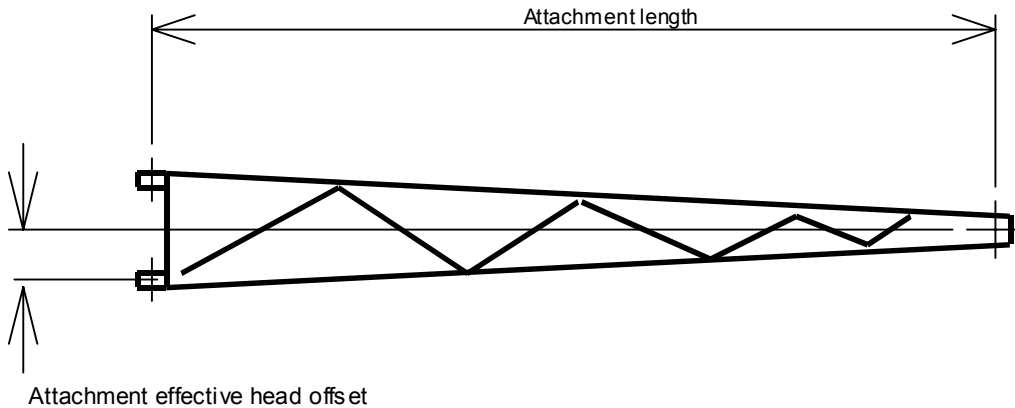

ATTACHMENT DATA CONTINUED

ATTACHMENT OFFSET ANGLE: Offset angle of attachment relative to main boom head (specify to nearest 0.1 degrees)

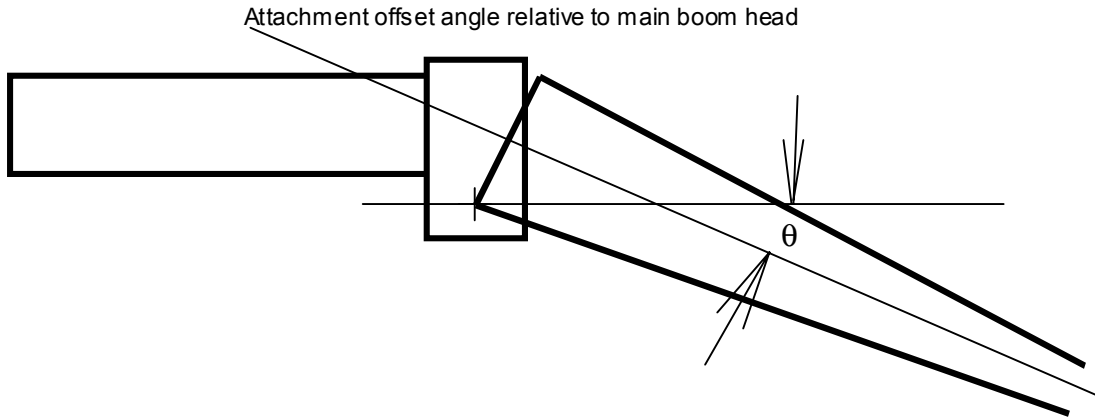

ATTACHMENT MOUNTING OFFSET

The following attachment mounting offset dimensions are usually not required, since most attachments are mounted to the main boom head sheave center.

Please indicate dimensions to nearest inch.

Attachment mounting offset (horiz): Distance between main boom head sheave center and center of attachment lower mounting point along boom centerline.

Attachment mounting offset (vert): Distance between main boom head sheave center and center of attachment lower mounting point perpendicular to boom centerline.

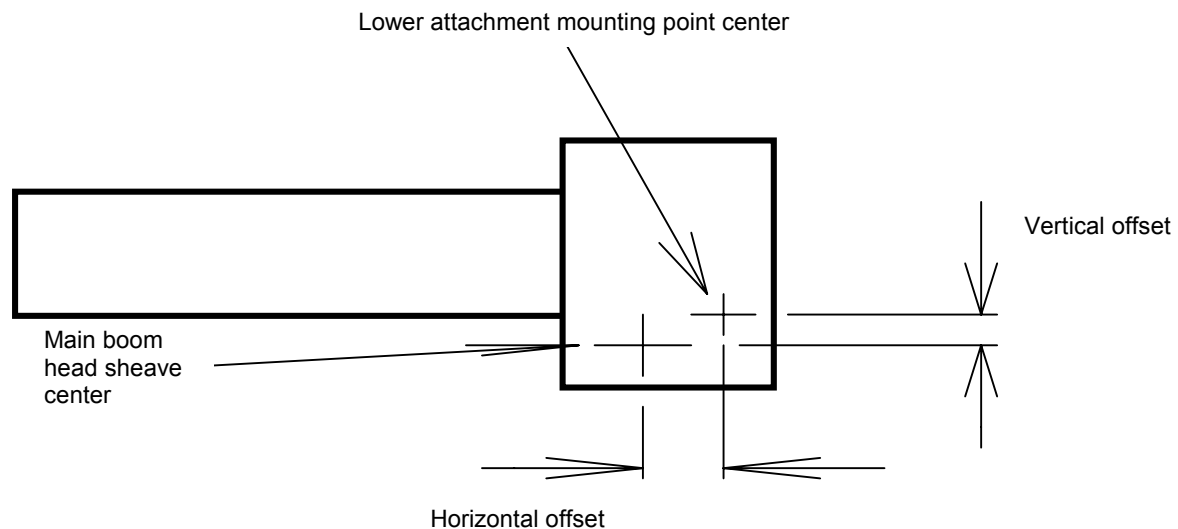

ATTACHMENT DATA CONTINUED

ATTACHMENT CENTER OF GRAVITY (ERECTED)

Please indicate dimensions to nearest inch.

Attachment center of gravity (horiz): Distance between attachment lower mounting point and center of gravity along attachment centerline.

Attachment center of gravity (vert): Distance between attachment lower mounting point and center of gravity perpendicular to attachment centerline.

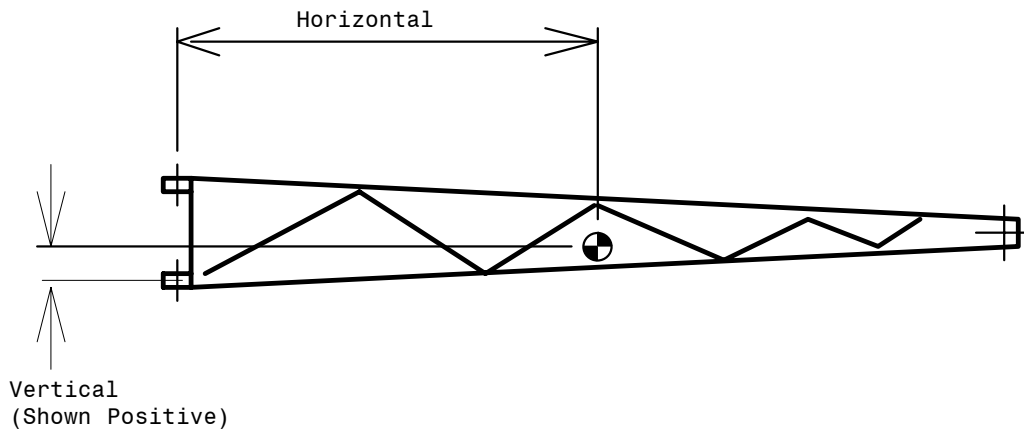

ATTACHMENT DATA continued

ATTACHMENT CENTER OF GRAVITY (STOWED)

Please indicate dimensions to nearest inch.

Stowed attachment center of gravity (horiz): Distance between main boom pivot and center of gravity along main boom centerline.

Stowed attachment center of gravity (vert): Distance between main boom pivot and center of gravity perpendicular to main boom centerline.

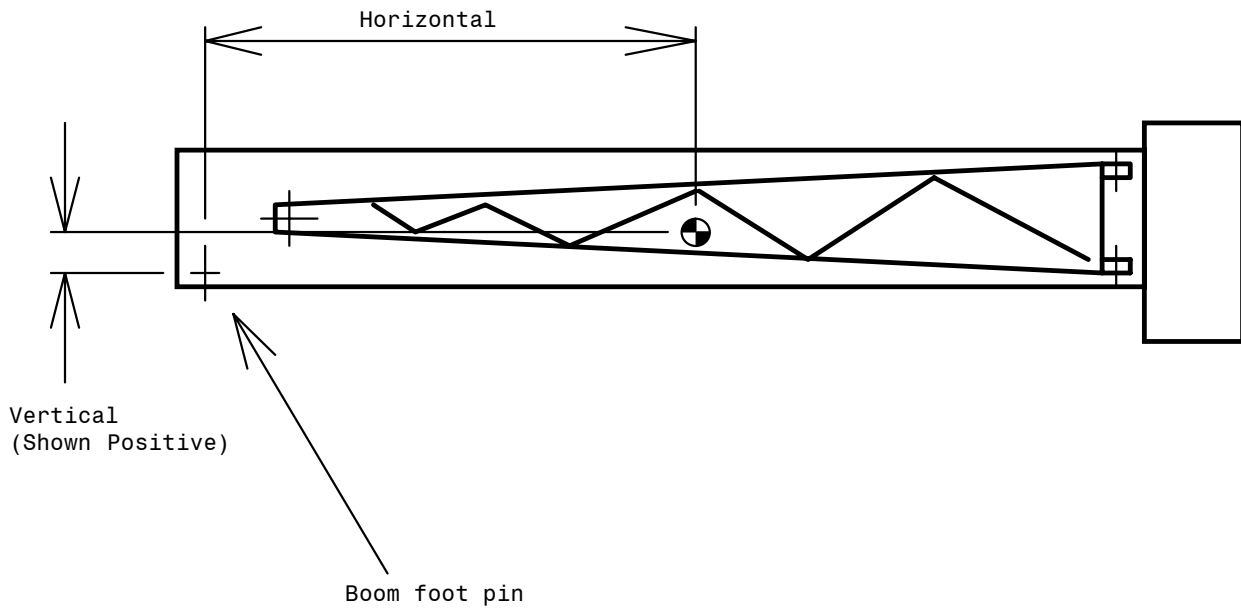

GREER COMPANY
Crane System

Attachment Data cont'd

	Attachment #1	Attachment #2	Attachment #3	Attachment #4	Attachment #5	Attachment #6
Attachment name						
l - Attachment length						
s - Attachment head offset						
h - Attachment mounting offset - horizontal						
v - Attachment mounting offset - vertical						
a - Attachment offset angles						
g - Attachment center of gravity - horizontal						
t - Attachment center of gravity - vertical						
w - Attachment weight						
r - Head sheave radius						

Stowed attachment data

g - Attachment center of gravity - horizontal						
t - Attachment center of gravity -vertical						
Stowed deduct wt.						
Erected deduct wt.						

APPENDIX A
EXTENSION REEL LAYOUT

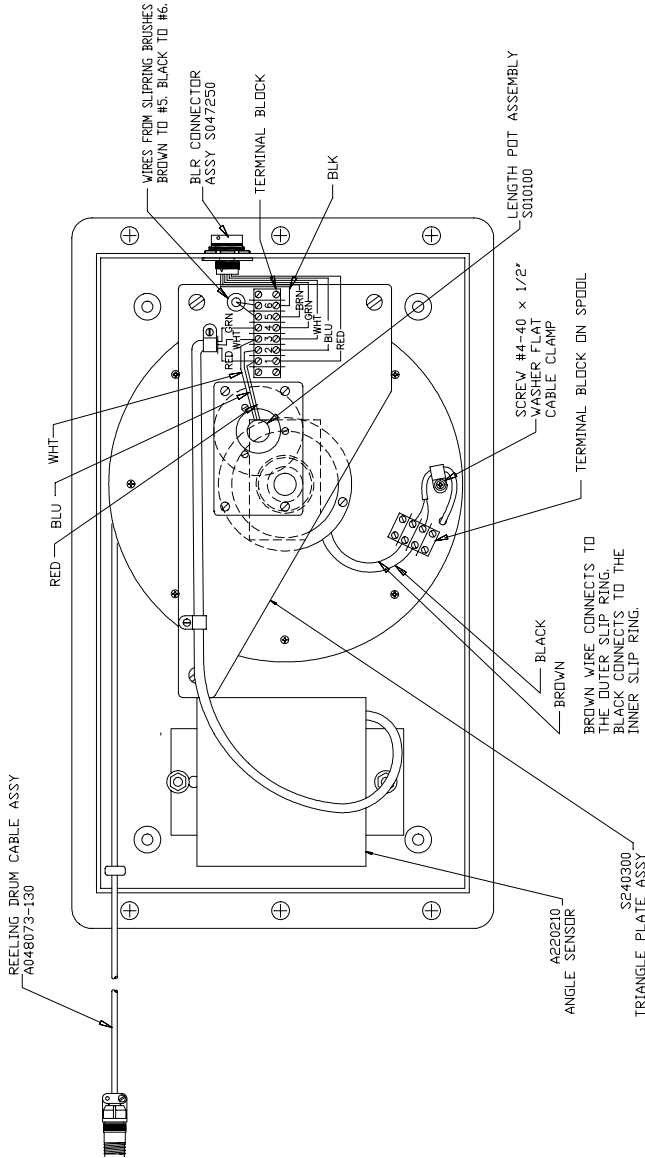

CONNECTIONS			
WIRE COLOR	TERM PIN NO.	CONNECTOR PIN NO.	SIGNAL NAME
RED	1	N	+ DRIVE
BLUE	2	E	LENGTH SIG
WHITE	3	D	-DRIVE (NOT GND)
GREEN	4	A	ANGLE SIG.
BROWN	5	G	BLOCK SIG.
BLACK	6	B	BLOCK GND.

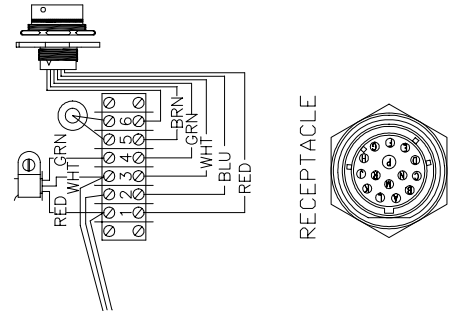

APPENDIX B

BULK HEAD CONNECTOR SCHEMATIC

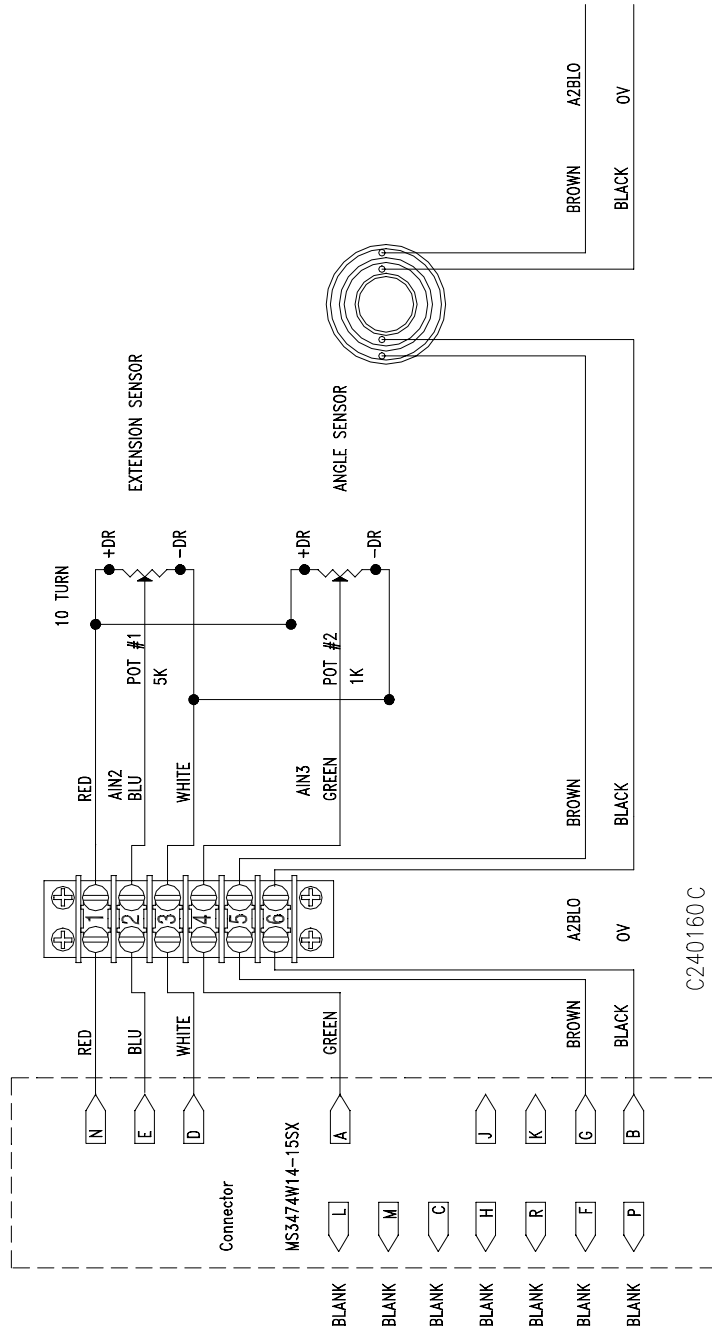

APPENDIX C

REEL TO COMPUTER CABLE ASSEMBLY

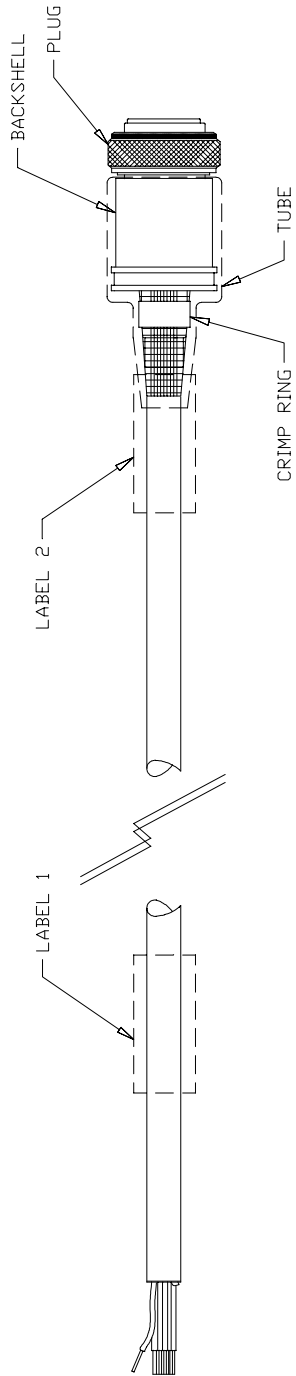

COLOR	PIN#	WIRE I.D.
RED	N	+DR
WHITE	E	AIN2
BLUE	D	-DR
GREEN	A	AIN3
BROWN	G	A2BIN
BLACK	B	OV
ORANGE	-	NONE
YELLOW	-	NONE

A047013 REV C

APPENDIX D

BULK HEAD CONNECTOR

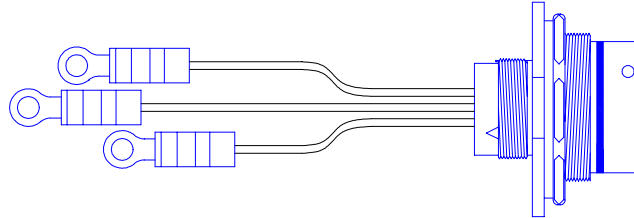

TERM	COLOR	PIN#	WIRE LENGTH	AWG	FUNCTION
4	GREEN	A	6.75	22	AIN 3
6	BLACK	B	6.00	22	0 V
3	WHITE	D	7.00	22	- DR
2	BLUE	E	7.50	22	AIN 2
5	BROWN	G	6.75	22	ATB IN
1	RED	N	7.75	22	+ DR

S047250 A

APPENDIX E

DISPLAY TO COMPUTER CABLE ASSEMBLY

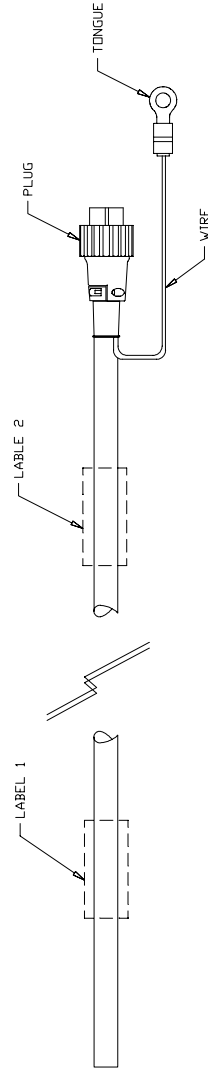

COLOR	PIN#	WIRE I.D.
CLEAR/WHITE	6	DA
BLACK	2	OV
ORANGE	4	OV
RED	1	+5VB
BLUE	8	RES
GREEN	7	DB
YELLOW	3	+5VA

A047062 C

APPENDIX F

EXTENSION REEL MOUNTING (hydraulic)

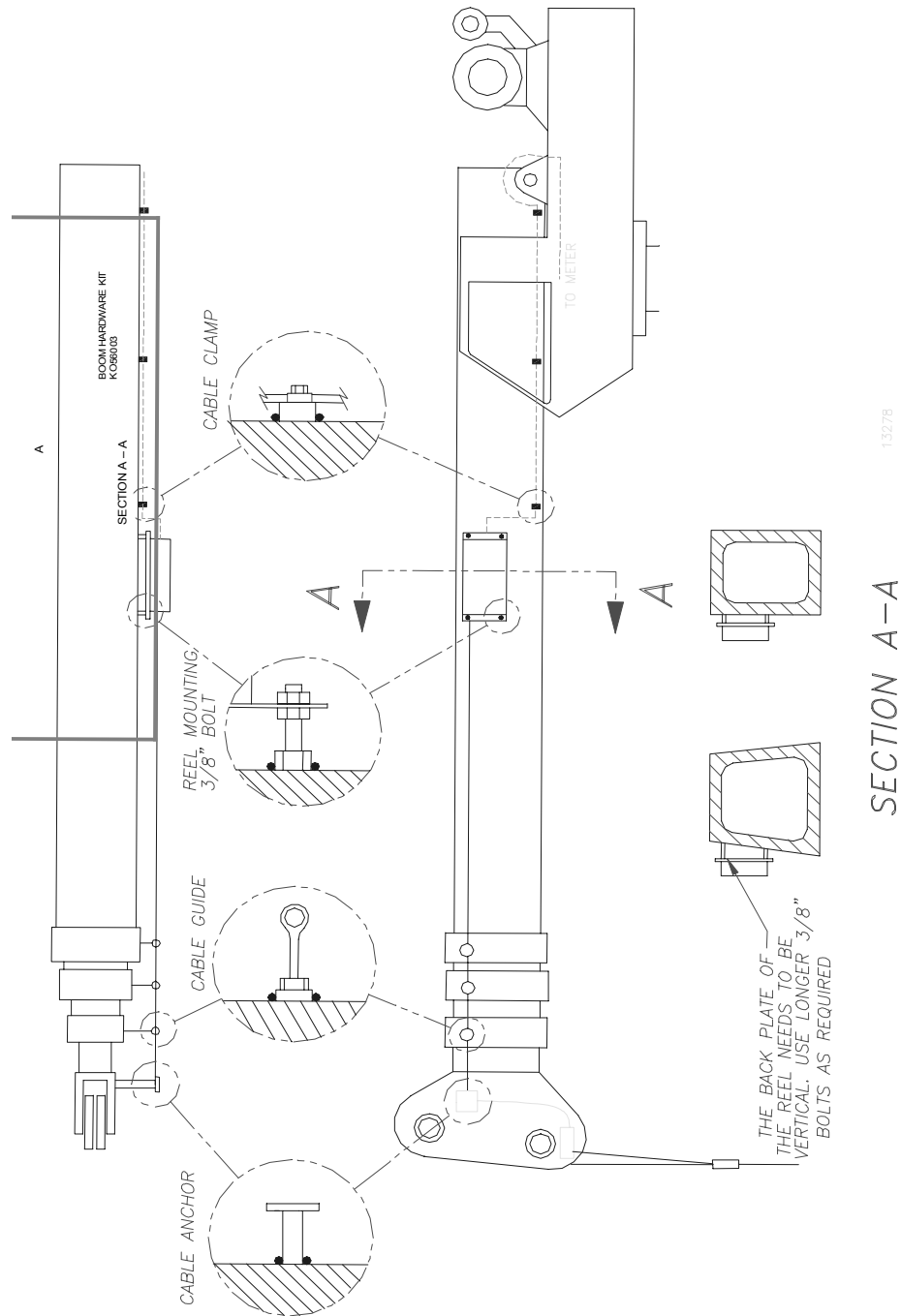

APPENDIX G

EXTENSION REEL MOUNTING (hydraulic)

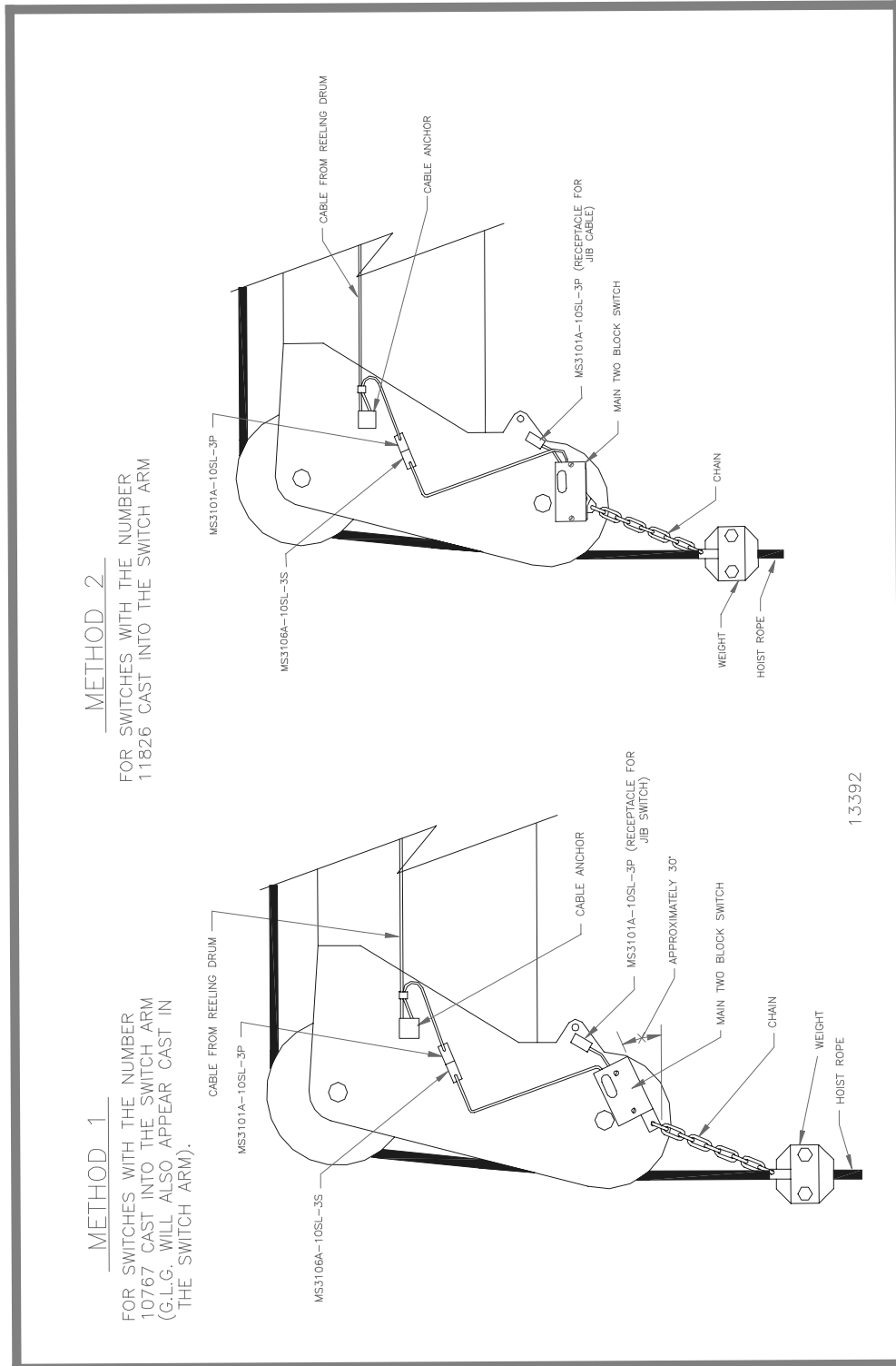

13392

GREER COMPANY SERVICE DEPARTMENT RETROFIT CALIBRATION REPORT

COMPLETE AND RETURN A COPY TO GREER ALONG WITH THE BACKUP PERSONALITY.

MACHINE TYPE	MACHINE SERIAL #	DUTY CHIP #	SYSTEM TYPE	DATE COMPLETED
COMPUTER	DISPLAY	REEL	ANGLE	ATB SERIAL #
P/N:	P/N:	P/N:	P/N:	MAIN
S/N:	S/N:	S/N:	S/N:	JIB/ AUX.

1. **Zero Analog Sensors**

TX0 _____ / _____
 TX1 _____ / _____
 Ain2 _____
 Ain3 _____

2. **Span Analog Sensors**

Ain2 _____ Ain3 _____
 Check angle indication: act/ind. _____ / _____ / _____ / _____

3. **Set Swing Pot or Check Swing Switches,** _____

4. **Pressure span :**

Actual load entered _____
 Radius measured _____
 Indicated load _____

5. **MAIN BOOM ONLY:**

Radius / Moment: Retracted low angle _____ measured radius _____
 High angle _____ measured radius _____
 Ind. length _____
 Mid extension low angle _____ measured radius _____
 High angle _____ measured radius _____
 Ind. length _____
 Full extension low angle _____ measured radius _____
 High angle _____ measured radius _____
 Ind. length _____

6. **Boom Deflection Correction** Actual load _____

Measured radius _____
 Radius entered _____ F value = _____
 Indicated load _____

7. **Annular gain test** _____

8. **ALTERNATE or TIP SECTION:**

Radius / Moment: Retracted low angle _____ measured radius _____

High angle _____ measured radius _____

Ind. length _____

Mid extension low angle _____ measured radius _____

High angle _____ measured radius _____

Ind. length _____

Full extension low angle _____ measured radius _____

High angle _____ measured radius _____

Ind. length _____

9. **Boom Deflection Correction:** Actual load _____

Measured radius _____

Radius entered _____ F value = _____.

Indicated load _____

10. **Manual BDC:** F= _____

11. **Jib BDC:** F= _____

12. Save and copy calibration _____.

Label chip with machine type and serial number. **Return copy chip to the Greer Company.**

13. System installed and calibrated by: _____

14. Crane Owner (Company) _____ Location _____

15. Date completed _____ Signature _____

COMMENTS:

