

The LINEMAN® 7TR Constant-Pull Traction Winch

Uniquely Designed for Multi-Use Trucks

The LINEMAN® 7TR is ideal for underground pulling applications and can be used on digger derricks, trailer-mounted pulling units, service bodies and other trucks, giving you the versatility to optimize your fleet.

There's Nothing Conventional About It.

Every rope layer on the LINEMAN 7TR traction winch delivers 7,000 lbs of constant pull and speed, helping you achieve more consistent operation, reduce costly wire rope failures, and increase rope life.

You Asked for It, So We Built It.

At dp Winch, we engineer innovative winch solutions to help our Utility customers work safer, smarter and more cost effectively.

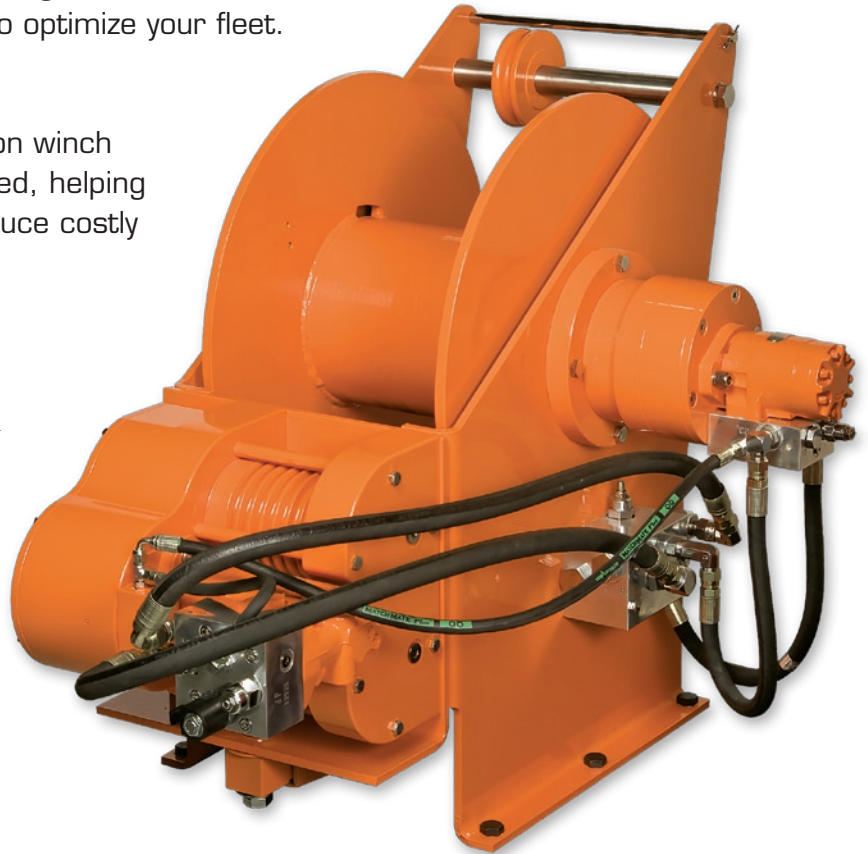

LINEMAN®

A Product of 

The LINEMAN 7TR delivers all the winch performance you expect with the versatility you never expected.

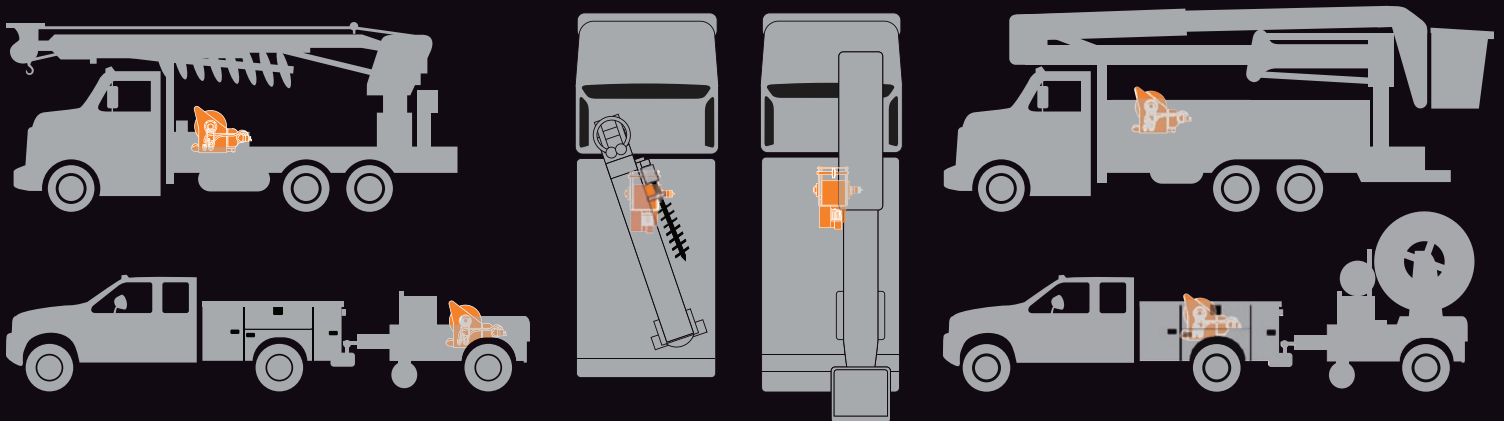

The LINEMAN® 7TR Constant-Pull Traction Winch

The LINEMAN® 7TR Traction Winch Features:

- 7,000 lb pulling capacity
- 2,000 ft of 3/8" wire rope capacity for long pulls with constant speed and pull
- Ideal for underground applications
- Compact design
- Increased rope life
- Cooler operating temperatures
- Less wear on internal parts
- Continuous-use duty cycles
- Lower hydraulic requirements
- Less maintenance

Performance Data

	Line Pull (lb)	Line Speed (pay-in) (fpm)*	Line Speed (pay-out) (fpm)
Speed:			
Low	7,000	45	56
High	3,500	82	111

Performance is based on 12 gpm @ 2,600 psi.
*Minimum pay-in speed at 12 gpm

Wire Rope Capacity

Wire Rope (in.)	Capacity (ft)
Ø3/8	2,000

7TR traction winches require up to 8 HP thermal cooling capacity from the hydraulic system.

Approximate weight 950 lb (less wire rope)

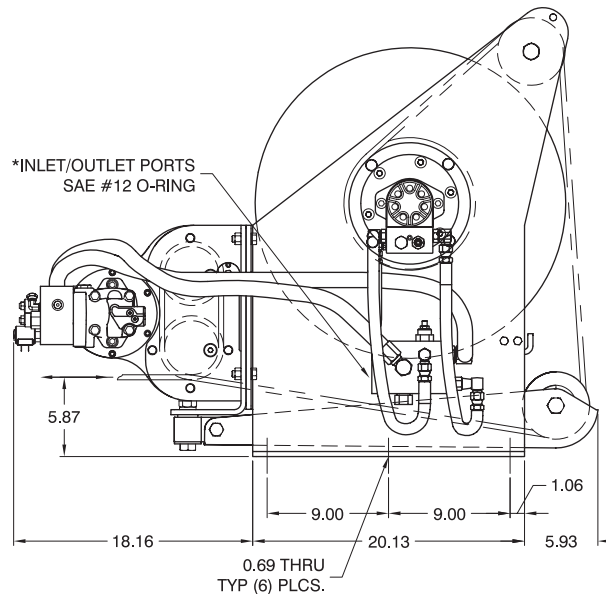
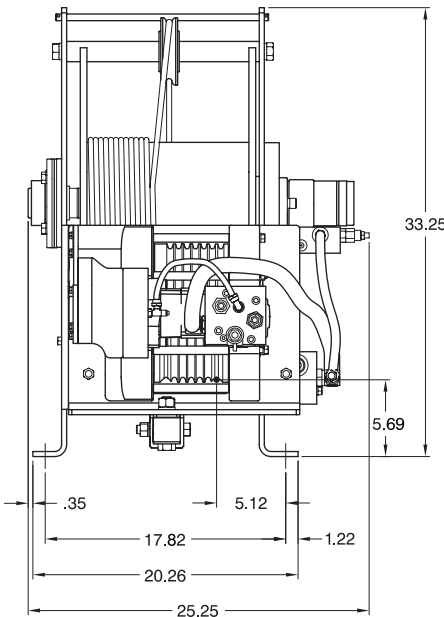

Typical Hydraulic System

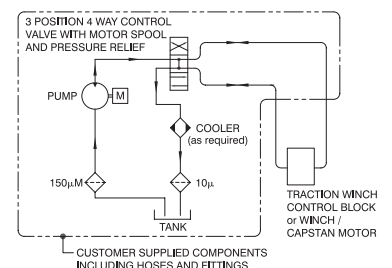

CAUTION:	WARNING:
The last 5 wraps of cable must be left on the drum to assist the cable clamp in holding the load.	Winches and capstans are not intended to be used for lifting or moving of persons.

Contact your dp sales representative for additional options and features not shown in this product catalog.

As a leader in product innovation, dp Winch is committed to the ongoing improvement of its equipment. We reserve the right to make changes to our products without notice.



P.O. Box 1130 | Jenks, OK 74037-1130
Voice: 918.298.8300 | Fax: 918.298.8301
www.dplineman.com



dp Winch is a part of Tulsa Winch Group, a global leader in standard and engineered winch, gearbox and load information systems.

LINEMAN® is a registered brand of dp Manufacturing, Inc.

© 2006 Tulsa Winch Group. All rights reserved. 36976 LINEMAN Orig. 0607